



Gate Valve

Standard Features

- Straight-through flow with minimal pressure drop
- Unique sliding cylindrical plug design provides larger seating area than conventional gate valves
- Made of durable, corrosion resistant plastic
- No metal to media contact anywhere in valve
- Clean-out (drain) plug in bottom area of valve body
- Rated for full vacuum service
- Light weight for easier and economical installation
- Positive bubble-tight shut-off
- Visual position indicator

Options

- 2" square operating nut
- Stem extensions
- Locking handles
- Electric actuation, up to 3"
- FKM seals

Caution

- Never remove valve from pipeline under pressure.
- Always wear protective gloves and goggles.

Specifications

Sizes: 1-1/2" - 14"
Body: High Impact PVC
Models: Flanged (ANSI)

Types/Sizes: "P" Type: PP, 1-1/2" - 14"
Seals: EPDM, FKM(Optional)

**Sizes 1 1/2" - 14" PVC/PP/EPDM/FKM
 Models available with NSF-61 Certification**

Type P Parts (Sizes 1-1/2" – 6")

PARTS			
NO.	DESCRIPTION	PCS.	MATERIAL
1	Body	1	PVC
2	Gate (Plug)	1	PP
3	Stem	1	PVC
4	Bonnet (A)	1	PVC
5	Bonnet (B)*	1	PVC
6	Thrust Bearing	1 Set	PP
7	Bolt, Nut, Washer	-	Stainless Steel 304
8	Hand Wheel	1	PP
9	Indicating Cover	1	PC
10	Indicating Ring	1	PVC
11	Guide Pin	1	Stainless Steel 304
12	Guide Pin Holder	1	PVC
13	Gasket	1	EPDM
14	O-Ring (A)	1	EPDM
15	Washer	1	PVC
16	Nut	1	Stainless Steel 304
17	O-Ring (B)	1	EPDM, Others
18	O-Ring (C)	2	EPDM, Others
23	Sheet Gasket	1	EPDM, Others
24	Plug	1	PVC

* Stem holder



Type P

Gate Valves

Sizes 1-1/2" - 6"

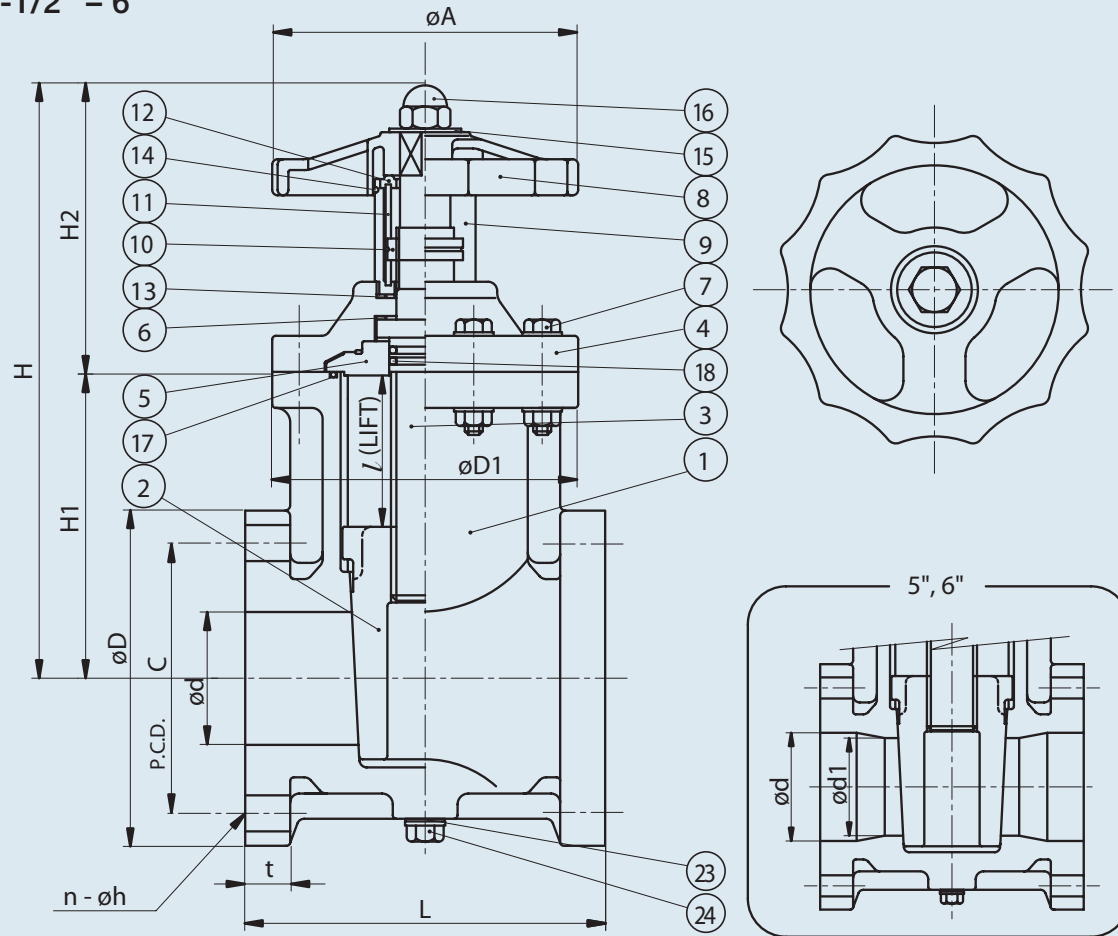

Troubleshooting

What if fluid still flows when fully closed?

1. Body or plug is worn or damaged. Replace.
2. Seat is worn or damaged. Replace.
3. Foreign material caught at the bottom of body. Needs cleaning.

What if handle does not engage with stem?

1. Stem damaged or broken. Change stem.

2. Engaging part of stem and/or plug damaged or broken. Need to replace stem and/or plug.

What if there are leaks between bonnet and body?

1. Bolts are not tightened properly. Tighten diagonally and evenly.
2. O-ring between body and bonnet damaged or worn. Change O-ring.

Dimensions (Sizes 1-1/2" - 6")

NOMINAL SIZE		ANSI CLASS 150													
INCHES	mm	d	d1	D	C	n	h	L	t	D1	A	l	H1	H2	H
1 1/2	40	1.57	-	5.00	3.88	4	0.62	6.50	0.87	4.72	4.72	1.93	4.21	5.20	9.41
2	50	1.97	-	6.00	4.75	4	0.75	7.01	0.91	5.12	5.12	2.36	5.28	5.35	10.63
2 1/2	65	2.56	-	7.00	5.50	4	0.75	7.48	0.94	6.10	6.10	2.95	5.98	5.91	11.89
3	80	2.95	-	7.50	6.00	4	0.75	7.99	0.98	6.69	6.69	3.35	6.69	6.10	12.79
4	100	3.94	-	9.00	7.50	8	0.75	9.02	1.06	7.68	7.68	4.33	8.15	6.42	14.57
5	125	4.92	4.33	10.00	8.50	8	0.88	10.24	1.06	9.25	9.25	4.61	8.94	7.09	16.03
6	150	5.91	5.12	11.00	9.50	8	0.88	10.51	1.06	10.63	10.63	5.43	10.35	7.17	17.52

Pressure vs. Temp. (PSI, WATER, NON-SHOCK)

NOMINAL SIZE		30° F 120° F
INCHES	mm	
1 1/2 - 8	40-200	150
10	250	110
12-14	300-350	75

Gate Valves

Type P

Type P Parts (Sizes 8" – 14")

Sizes: 8" – 14"

PARTS			
NO.	DESCRIPTION	PCS.	MATERIAL
1	Body	1	PVC
2	Gate (Plug)	1	PP
3	Stem	1	PVC
4	Bonnet (A)	1	PVC
4a	Bush (A)	1	PP
4b	Knock Pin (A)	1	PP
5	Bonnet (B)*	1	PVC
5a	Bush (B)	1	PP
5b	Knock Pin (B)	1	PP
6	Thrust Bearing	1 Set	High Carbon Chromium
7	Bolt, Nut, Washer	-	Stainless Steel 304
8	Hand Wheel	1	PP
9	Indicating Cover	1	PC
10	Indicating Ring	1	PVC
11	Guide Pin	1	Stainless Steel 304
12	Guide Pin Holder	1	PVC
13	Gasket	1	EPDM
14	O-Ring (A)	1	EPDM
15	Washer	1	PVC
16	Nut	1	Stainless Steel 304
17	Screw	1	Stainless Steel 304
18	O-Ring (B)	1	EPDM, Others
19	O-Ring (C)	3	EPDM, Others
20	O-Ring (D)	1	EPDM, Others
21	O-Ring (E)	1	EPDM, Others
22	O-Ring (F)	1	EPDM, Others
23	Sheet Gasket	1	EPDM, Others
24	Plug	1	PVC
1a	Body Metal Inserts**	-	Copper Alloy

* Stem holder

** 8" and 12" sizes: 4 inserts; 14" size: 8 inserts

Sample Specification

All Gate Valves shall be constructed of High Impact PVC and have no metal-to-media contact. The gate shall be a tapered cylindrical plug design PVC shall conform to ASTM D1784 Cell Classification 12454-A, & PP to ASTM D4101 Cell Classification PP0210B67272. Valves shall have a pressure rating of 150 psi at 70 degrees F sizes 1-1/2" through 8", 110 psi at 70 degrees F size 10", and

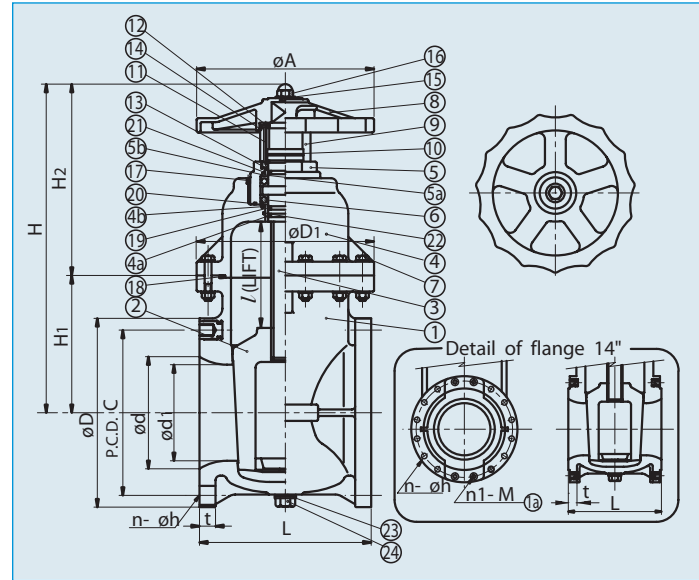

Cv Values

NOMINAL SIZE		Cv
INCHES	mm	
1 1/2	40	130
2	50	180
2 1/2	65	415
3	80	470
4	100	690
5	125	1000
6	150	1400
8	200	2900
10	250	3700
12	300	5200
14	350	7000

Weight (POUNDS)

NOMINAL SIZE		FLANGED
INCHES	mm	
1 1/2	40	7.50
2	50	10.20
2 1/2	65	13.00
3	80	16.60
4	100	22.00
5	125	29.00
6	150	42.00
8	200	68.50
10	250	95.00
12	300	150.00
14	350	188.00

75 psi at 70 degrees F sizes 12" and 14". The valve shall have a non-rising stem, come standard with sealed position indicator, clean-out plug and EPDM or FKM seals as manufactured by Asahi/America Inc.

Dimensions (Sizes: 8" – 14")

NOMINAL SIZE		ANSI CLASS 150							L	t	D1	A	l	H1	H2	H
INCHES	mm	d	d1	D	C	n	h	n1 – M								
8	200	7.72	6.61	13.50	11.75	6	0.88	2 – 3/4 UNC	11.50	1.10	12.20	12.20	7.09	9.45	13.27	22.72
10	250	9.72	8.27	16.00	14.25	12	0.98	-	14.96	1.18	14.17	14.17	8.90	10.63	16.54	27.17
12	300	11.73	10.04	19.00	17.00	10	0.98	2 – 7/8 UNC	15.75	1.22	16.14	16.14	10.75	12.60	18.90	31.50
14	350	13.70	11.69	21.00	18.75	8	1.14	4 – 1 UNC	16.93	1.26	17.32	17.91	12.56	12.20	23.62	35.83

Authorized Distributor:

Aetna Plastics Corp. 1702 St. Clair Ave. Cleveland, Ohio 44114 • Tel: 800-634-3074
216-781-4421 • Fax: 216-781-4474 • sales@aetnaplastics.com • www.aetnaplastics.com