



Type A Pressure Relief Valve

Specifications

Sizes: 1/2" - 2"

Materials: PVC and PP

Models: 1) Threaded PVC 1/2" - 2"
PP 1/2" - 1"
2) Flanged PVC 1/2" - 2"
PP 1/2" - 2"

Seals: EPDM, FKM

Max.Line Pres: PVC 110 psi
PP 85 psi

Setting Range: PVC 5 - 100 psi
PP 5 - 75 psi

Standard Features

- Most extensive size range in the industry
- U-cup seals protect spring chamber while maintaining sensitive operation
- Designed for fewer flow restrictions and excellent flow capacity
- Repaired in line, easy maintenance
- Stainless Steel adjustment feature provides convenient relief pressure setting in the field (Factory set at no additional charge)

Sample Specification

All Pressure Relief Valves shall be of Thermoplastic construction, (PVC or PP) and have no metal part that comes in contact with media. PVC shall conform to ASTM D1784 Cell Classification 12454-A and PP conforming to ASTM D4101 Cell Classification PPO210B67272. PVC valves shall be rated to 110 psi sizes 1/2" thru 2" and 75 psi sizes 2-1/2" thru 4", PP rated to 75 psi sizes 1/2" thru 4" at 70 degrees F, as manufactured by Asahi/America, Inc.

Troubleshooting

What if valve does not open fully?

1. Not enough overpressure is being applied to valve. Reset.

What if valve does not seat fully?

1. Foreign particles may be caught between the seat and plug. Clean seat and plug area.
2. Plug and seat may be damaged or worn. Replace plug and seat.
3. Line pressure is not below set pressure. Check line pressure and reset.

Parts List (Sizes 1/2" - 2")

PARTS		
NO.	DESCRIPTION	MATERIALS
1	Body	PVC, PP
2	Bonnet	PVC, PP
3	Seat	PVC, PP
4	Orifice Seal	EPDM, FKM
5	Piston	PVC, PP
6	Guide Bushing	PVC, PP
7	Bonnet Spacer	PVC, PP
8	Upper Spring Keeper	PVC, PP
9	Lower Spring Keeper	PVC, PP
10	Adjustment Screw Guide	300 SS
11	Spring	17-7 SS
12	5/8 Washer	Stainless Steel
13	Adjustment Screw	316 SS
14	Seal Kit	EPDM, FKM
15	5/8 Hex Nut	316 SS
16	1/4 Hex Screw	316 SS
17	5/16 Hex Screw	316 SS
18	Seat Spacer	316 SS
19	Cap	PVC, PP
20	Spring Housing	PVC, PP

Caution

- The valves are not safety devices and must not be substituted for code approved safety relief valves or rupture discs.
- Never remove valve from pipeline under pressure.
- Always wear protective gloves and goggles.

Type A Pressure Relief Valves

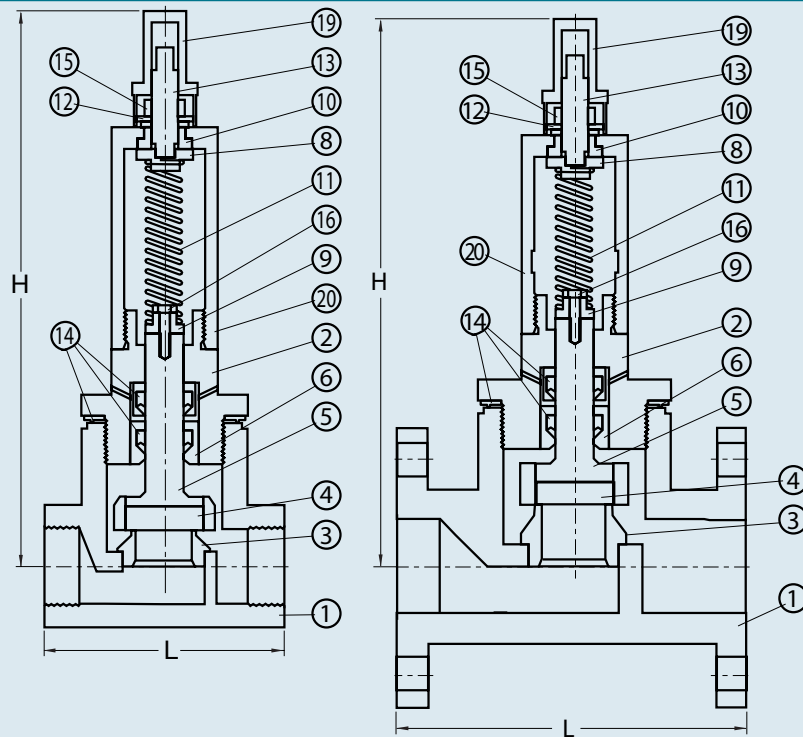

Dimensions (Thr'd 1/2" - 2")

NOMINAL SIZE		L	H
INCHES	mm		
1/2	15	3.36	9.30
3/4	20	3.74	9.40
1	25	4.33	9.40
1 1/2	40	5.51	12.70
2	50	7.09	13.00

Dimensions (Flange 1/2" - 2")

NOMINAL SIZE		L	H
INCHES	mm		
1/2	15	3.36	9.30
3/4	20	3.74	9.40
1	25	4.33	9.40
1 1/2	40	7.48	12.70
2	50	7.87	13.00

Pressure vs. Temperature (PSI)

NOMINAL SIZE		PVC			PP		
		30° F 70° F	71° F 105° F	106° F 120° F	-5° F 70° F	71° F 140° F	141° F 175° F
1/2 - 1 1/2	15-40	110	75	75	85	65	45
2	50	110	75	65	85	50	30

Ordering Information

Step 1. Determine Set Pressure

(110 psi: Max. pres. rating for PVC valve)

(85 psi: Max. pres. rating for PP valve)

1. Max. allowable working pressure (MAWP¹) for system _____ psi:
2. Overpressure² _____ psi:
3. Set pressure (normally 15 psi over operating pressure) _____ psi:
4. Normal operating pressure _____ psi:

¹ MAWP: Max. safe system pressure

² Overpressure: Amount of additional pressure required for disc to attain full lift, and therefore, full flow capacity. The Asahi/America design attains full lift at 25% overpressure.

Step 2. Service Conditions

1. Media: _____ % Concentration: _____
Temp: _____ (°F or °C)
2. Ambient Temperature: _____ (°F or °C)
3. Pipe Size: _____ Material: _____
4. Body Material: PVC _____ Polypropylene _____
5. End Connections: NPT Threaded _____
150# ANSI Flat Faced Flanges _____
6. Downstream Pressure: _____ psig
7. Flow Rate (gpm): Normal _____ or Cv
Required _____ Max _____ Mini _____

Authorized Distributor:

Aetna Plastics Corp. 1702 St. Clair Ave. Cleveland, Ohio 44114 • Tel: 800-634-3074
216-781-4421 • Fax: 216-781-4474 • sales@aetnaplastics.com • www.aetnaplastics.com