



## Pressure Relief Valves

1/2" to 2" - PVC and Corzan® CPVC



### Features

- No Metal Parts to Stick or Jam
- Hand Adjustable
- Molded Gauge Port
- Relieves Pressures from 5 to 75 PSI
- All Plastic, No Rust or Corrosion
- FPM or EPDM Seals

### Options

- Pressure Gauges
  - 0 to 30 PSI
  - 0 to 60 PSI
  - 0 to 160 PSI
- Gauge Guards
- Low Pressure Springs

### Reliable Pressure Relief

Hayward Pressure Relief Valves protect piping system components from damage due to overpressurization. The valves work by sensing system pressure. When the system pressure exceeds the set pressure, the force of the excess pressure moves the valve piston off its seat to relieve the excess pressure and diverts some of the flow out the discharge port.

### Easy to Set Pressure

Hayward Pressure Relief Valves can be set by hand – no tools are needed – to relieve pressures from 5 to 75 PSI. Each size of relief valve is designed to cover this complete pressure range with just one, non-wetted, plastic-coated spring. There's no need to change springs for different pressure ranges as with ordinary relief valves.

### Molded Gauge Port

An integrally-molded 1/4" NPT gauge port on the valve body makes installation of a gauge to monitor the relief pressure easy. No drilling or extra fittings are needed.

### No Corrosion Failure

These all-plastic relief valves have no metal parts and will never fail, jam, or stick because of rusted or corroded components. They also require no painting or epoxy coatings to survive corrosive environments.

### Spring Options

The 1/2" and 2" sizes have an optional low pressure spring. The use of this spring changes the adjustment range to 2 through 20 PSI.



## Technical Information

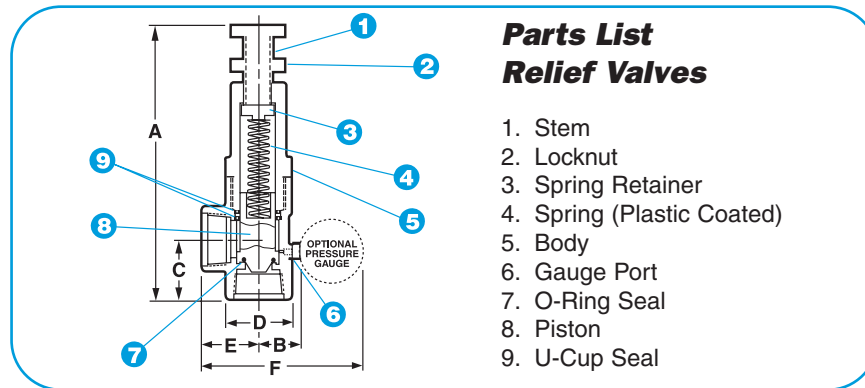

### Parts List Relief Valves

1. Stem
2. Locknut
3. Spring Retainer
4. Spring (Plastic Coated)
5. Body
6. Gauge Port
7. O-Ring Seal
8. Piston
9. U-Cup Seal

### Dimensions - Inches / Millimeters

Size	A	B	C	D	E	F	Weight (lb / kg)
1/2"	6.75 / 171	1.38 / 35	1.50 / 38	1.38 / 35	1.38 / 35	5.19 / 132	0.50 / .23
3/4"	6.88 / 175	1.50 / 38	1.75 / 44	1.56 / 40	1.63 / 41	5.44 / 138	0.75 / .34
1"	8.75 / 222	1.63 / 41	2.06 / 53	1.88 / 48	1.88 / 48	5.75 / 146	1.00 / .45
1-1/2"	13.25 / 337	1.88 / 48	2.63 / 67	2.63 / 67	2.44 / 62	6.25 / 159	2.50 / 1.14
2"	15.50 / 394	2.13 / 54	3.00 / 76	3.13 / 80	2.88 / 73	6.69 / 170	3.50 / 1.59

### Selection Chart

Size	Material	End Conn.	Seals	Pressure Setting	Pressure Rating
1/2" to 2"	PVC or CPVC	Threaded	FPM or EPDM	5 to 75 PSI*	150 PSI** @ 70°F Non-Shock

\* Optional 2-20 PSI for 1 1/2", and 2" valves with low pressure spring  
 \*\* Inlet pressure over 75 PSI cannot be regulated

### Relief Valve Flow Chart

The chart below shows the flow rate out of the relief valve discharge port at a given set pressure and overpressure. For example, a 1" relief valve set to relieve at 30 PSI would have a flow rate of 20 GPM out of the discharge port at 10 PSI of overpressure (system pressure at 40 PSI).

### Operating Temperature/Pressure

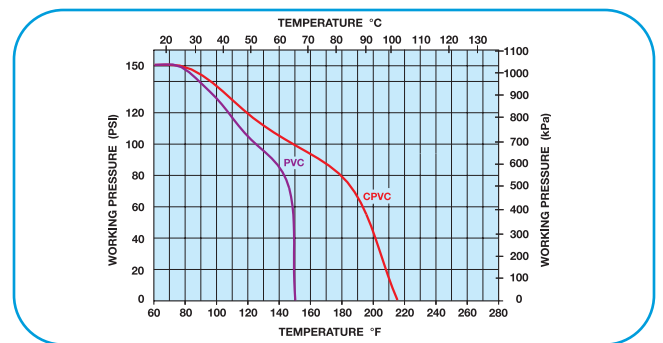

Set Relief Pressure (PSI)	Relief Valve Sizes (NPT)															
	1/2"			3/4"			1"			1-1/2"			2"			
	Overpressure (PSI)			Overpressure (PSI)			Overpressure (PSI)			Overpressure (PSI)			Overpressure (PSI)			
	+5	+10	+20	+5	+10	+20	+5	+10	+20	+2*	+5*	+5	+10	+20	+2*	+5*
Flow Rate (gpm)																
10	.5	2.0	6.0	3.0	4.0	9.0	7.0	11.0	18.0	1.0	15.0	20.0	22.5	110.0		
20	1.0	3.0	7.0	4.0	6.0	15.0	8.0	14.0	24.0	1.5	30.0	33.0	40.0	125.0		
30	1.0	3.0	8.0	5.5	9.0	17.5	8.0	20.0	27.0	5.0	40.0	45.0	55.0	147.0		
40	1.0	3.0	8.0	9.0	13.0	19.0	8.0	27.5	30.0	8.0	47.5	51.0	75.0	160.0		
50	-	-	-	9.0	15.0	21.0	8.0	33.0	36.0	10.0	69.0	72.0	83.0	180.0		
75	-	-	-	9.0	18.0	20.0	8.0	40.0	48.0	10.0	90.0	96.0	92.0	180.0		

\* With optional low pressure spring

Authorized Distributor:

Aetna Plastics Corp. 1702 St. Clair Ave. Cleveland, Ohio 44114 • Tel: 800-634-3074  
 216-781-4421 • Fax: 216-781-4474 • sales@aetnaplastics.com • www.aetnaplastics.com