

New!

Compact & Economical PTFE Bellows Thermoplastic Solenoid Valve...

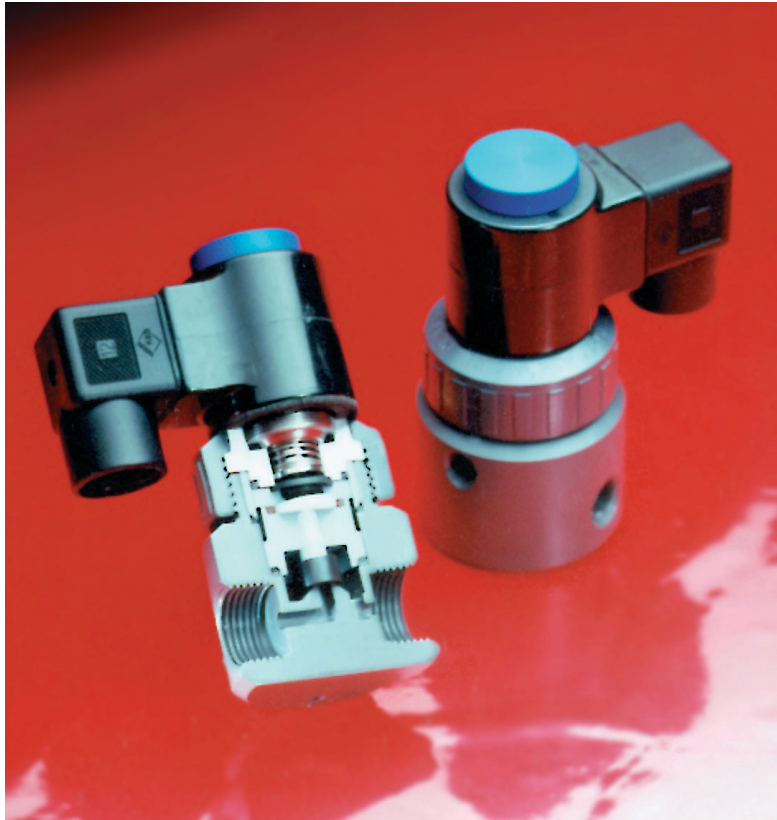

For applications requiring a compact, cost-effective and high-pressure rated valve with extended cycle life.

Features:

- **Compact Size:** Only 4-9/16" high, these valves are ideal for limited space installations.
- **Economical:** Low unit cost coupled with high pressure ratings and considerable flow rates (Cv of 0.5 or 0.8) offer excellent opportunities for systems requiring quick opening/quick closing solenoid valves.
- **High Pressures:** Particularly for applications where high back-pressures (up to 70 PSI) are required e.g. controlling flow to spray nozzles, high pressure chemical injections, etc. Inlet pressure to 140 PSI.
- **Unique Design:** PTFE Bellows barrier type dynamic seal prevents leaking of fugitive emissions to the atmosphere.
- **Versatility:** Can be used with all type solutions. Includes acids, caustics, solvents, chlorine solutions and ultra-pure liquids. For pressure, drain or vacuum service.

- **Superior Performance:** 2,000,000 cycle design.
- **Energy Efficient:** Molded 11 watt NEMA 4X style coil with DIN standard connector results in low energy consumption.
- **Sizes:** 1/4" and 1/2" pipe sizes with 3/16" (4.8 mm) or 1/4" (6.4 mm) orifice.
- **Corrosion Resistant:** Rugged thermoplastic construction is resistant to both internal and atmospheric corrosion. No metal parts in wetted areas.
- **Safety/Dependability:** Patented Fail-Dry® safety design feature provides advance visual warning if seal malfunctions, while permitting valves to continue operating until maintenance can be scheduled.
- **Coil Connector Light:** Can be ordered with this optional feature, which lights up brightly to show when the solenoid is energized.
- **Material Construction:** *Bodies:* PTFE Bellows solenoid valve bodies are available in PVC, Polypropylene, and PVDF (Kynar®). *Seals:* Standard seal material for all Bellows solenoid valves is a special treated Viton®, so that a single valve can handle virtually all types of solutions. Multi-purpose capability results in significant convenience and cost-efficiency. EPDM also available.

PTFE BELLOWS THERMOPLASTIC SOLENOID VALVES

Design and Operation:

Valves are spring return normally closed and direct acting with a simple push-pull plunger design. There is no minimum pressure required for operation. The PTFE bellows shaft seal eliminates the need for an elastomer seal which can weaken as a result of chemical attack. The PTFE bellows assures non sticking operation and exceptionally long cycle life; over 2 million cycles. The bellows design also allows a stock valve to be used for vacuum or pressure. The poppet seat insures bubble tight shutoff.

Pressure Rating Considerations:

Inlet Pressure: Inlet pressure rating in the tables below are at full rated line voltage for alternating current (A.C.). If line voltage is 10% lower, inlet pressure rating will be about 30% lower. If rated pressures are exceeded the valve will not open and the coil will burn out.

Outlet (Back) Pressure: An important consideration in solenoid valve selection is back pressure rating (max. outlet) shown in the spec table. Back pressure is caused by the resistance to flow in the piping downstream of the valve and is the most common source of solenoid valve problems during start up. Nozzles, goosenecks, fittings, tubing, or reduced outlet piping all create restrictions that raise the back pressure so these sources must be considered in planning a piping system. Although the EAST valve is capable of handling high back pressures, values shown in the spec table should not be exceeded.

W11 Coil:

This new continuous duty NEMA 4X style coil is water and dust tight, and is suited for corrosive atmospheres compatible with polyester. Most coils CSA certified.

Insulation Class: F
 Coil Surface Temperature: 185°F (85°C)
 Max. Allowable Ambient Temperature: 104°F (40°C)
 VA Inrush: 66 VA Holding: 24

Temperature Reference Material:

The chart below is to provide overall guidelines on various thermoplastics relative to their pressure and temperature relationships. The information should be used to determine limitations of the various materials.

MATERIAL TEMPERATURE VS. PRESSURE															
MAT'L	MAX. TEMP. RATING	Maximum Inlet Pressure and Temperature													
		75°F (24°C) PSI BARS		110°F (43°C) PSI BARS		140°F (60°C) PSI BARS		180°F (82°C) PSI BARS		220°F (105°C) PSI BARS		240°F (116°C) PSI BARS		284°F (140°C) PSI BARS	
PVC	140°F (60°C)	140	9,6	100	6,8	40	2,7	N.R.	N.R.	N.R.	N.R.	N.R.	N.R.	N.R.	N.R.
PP*	180°F (82°C)	140	9,6	100	6,8	80	5,4	40	2,7	N.R.	N.R.	N.R.	N.R.	N.R.	N.R.
PVDF	284°F (140°C)	140	9,6	130	8,8	120	8,2	100	6,8	60	4,1	30	2,0	10	0,7

*NATURAL POLYPROPYLENE

N.R. = NOT RECOMMENDED

Design and Operation:

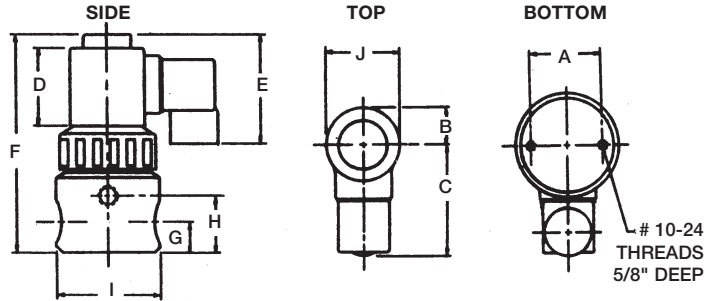

Pipe Size	A		B		C		D		E	
	In.	mm	In.	mm	In.	mm	In.	mm	In.	mm
1/4 & 1/2	1 1/2	38.1	3/4	19.0	2 5/8	66.7	1 5/8	41.3	1 5/16	58.7

Pipe Size	F		G		H		I		J	
	In.	mm	In.	mm	In.	mm	In.	mm	In.	mm
1/4 & 1/2	4 9/16	115.9	5/8	15.9	1 3/16	30.2	2 5/32	54.8	1 1/2	38.1

Specifications & Model Numbers:

Pipe Size	Orifice Size	In.	mm	Watts	C _v	Max. Inlet PSI / Bar	Max. Outlet PSI / Bar	Model Number w/Viton® Seals
1/4"	3/16	4.8	11	0.5	140 / 9.5	70 / 4.8	EAST2V6W11	
1/4"	1/4	6.4	11	0.8	70 / 4.8	60 / 4.1	EAST2V8W11	
1/2"	3/16	4.8	11	0.5	140 / 9.5	70 / 4.8	EAST4V6W11	
1/2"	1/4	6.4	11	0.8	70 / 4.8	60 / 4.1	EAST4V8W11	

NOTES:

- 1) All Model Numbers must be completed with body material at the end as follows: PVC with "-PV", Polypropylene with "-PP" and PVDF (Kynar®) with "-PF". ex: EAST2V6W11-PV.
- 2) The Model Numbers listed show Viton seals. For EPDM seals (optional) change "V" to "EP". ex: EAST2EP6W11.
- 3) Model Numbers shown with "W11" (water & dust tight NEMA 4X style coil).
- 4) Valves are rated for full vacuum of 30" of mercury (Hg).
- 5) Standard voltages are 110/50, 220/50, 120/60, 230/50, 240/60 AC and 24 VDC (DC coil not recommended with 1/4" orifice). For other voltages, minimum quantities required.

Sample Specification: Thermoplastic [enter valve body material here] solenoid valve, [enter pipe size here] NPT threads is to be the direct-acting, shield core design. No minimum pressure nor pressure differential is required for operation. The solenoid valve is to have two primary sealing components, a PTFE bellows dynamic seal with [enter Viton or EPDM] poppet seat and a secondary elastomer diaphragm back-up seal with a Fail-Dry® advance warning safety vent. Each valve is to be individually tested for leaks. As manufactured by Plast-O-Matic Valves, Inc., Cedar Grove, NJ.

Authorized Distributor:

**Aetna Plastics Corp. 1702 St. Clair Ave. Cleveland, Ohio 44114 • Tel: 800-634-3074
 216-781-4421 • Fax: 216-781-4474 • sales@aetnoplastics.com • www.aetnoplastics.com**