

Sight Glasses & Level Indicators

Safe Indication of Flow, Clarity or Exact Level of Extremely Corrosive and Ultra-Pure Liquids



Standard Sight Glasses



Custom Products



Level Indicators

Features:

- Large 360° viewing area
- Series GY, GYW and GL have double wall Pyrex® and acrylic construction for maximum safety.
- Full flow design; no corners to collect debris.
- Wide choice of select plastic materials to assure maximum chemical compatibility.
- Designed to withstand reasonable external shocks.
- Little or no maintenance required.
- No special hardware required for installation; completely assembled and pre-tested.

Design:

Plast-O-Matic flow and level indicators are designed to indicate the presence or clarity of liquid in a piping system or to indicate level in a tank. They offer a maximum viewing area with a full 360° visibility for dependable observation and inspection from a reasonable distance.

With the exception of the Series GX flow indicator, which can only be used for liquids compatible with acrylic, all Plast-O-Matic indicators utilize double-wall construction.

O-ring seals are used on all Plast-O-Matic indicators allowing them to seal at extremely low pressures as well as high pressures. In the Series GYW wafer-style flow indicators, O-ring seals are also supplied for both ends eliminating the need for flange gaskets.

Materials of Construction:

Ends on Series GX indicators are PVC or natural polypropylene. Ends on Series GY and GL indicators are PVC, natural polypropylene or PTFE. Ends on Series GYW indicators are PVC, Corzan® CPVC, natural polypropylene, PTFE or Kynar® PVDF.

Standard O-ring seals on Series GX indicators are either Buna-N or FKM. On Series GY, GYW and GL indicators, FKM O-rings are standard. For additional seal materials, consult factory.

Standard fasteners are stainless steel on Series GX, GY, and GYW flow indicators. Fasteners are not used on Series GL level indicators.

All inner walls are Pyrex® for maximum corrosion resistance, and all outer walls are high impact acrylic which acts as an armored shield against shocks. Acrylic cylinder walls are ultra-violet resistant.

Fluttering Devices:

All Plast-O-Matic flow indicators can be used to indicate the presence of liquid flow when the liquid lends itself to turbulence or has entrained air bubbles. When the liquid is either clear or opaque, a mechanical device is required to identify liquid movement. Optional vinyl streamers that flutter in the presence of flow are available for Series GX and GY flow indicators. An optional FKM device is available for Series GYW.

SERIES GX • Single Cylinder Wall Flow Indicators

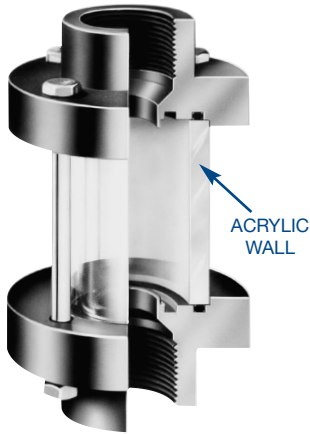

Series GX flow indicators have a single clear acrylic cylinder wall and are used to indicate flow or clarity of ultra-pure liquids such as demineralized water. They may also be used with corrosive chemicals that are compatible with acrylic. They are available with PVC or natural polypropylene ends and with either Buna-N or FKM seals. Pipe sizes are 1/2" through 3" NPT. BSP (British Standard Pipe) threads are also available. Optional fluttering streamers are also offered. Please consult page 4 for pressure and temperature specifications.

SERIES GX - SIGHT GLASS DIMENSIONS							
Pipe Size	"A" Visual Length In.	"A" Visual Length mm	"B" End/End Length In.	"B" End/End Length mm	"C" Diameter In.	"C" Diameter mm	"D" Diameter In. mm
1/2"	2 1/4	57.1	4 3/4	120.6	1 1/2	38.1	2 1/2 63.5
3/4"	2 1/4	57.1	4 3/4	120.6	1 1/2	38.1	2 1/2 63.5
1"	2 1/4	57.1	5 1/4	133.3	1 3/4	44.4	3 76.2
1 1/4"	2 1/2	63.5	5 7/8	149.2	2 3/8	60.3	3 1/2 88.9
1 1/2"	2 1/2	63.5	5 7/8	149.2	2 3/8	60.3	3 1/2 88.9
2"	3 1/8	79.3	7 3/8	187.3	2 7/8	73.0	4 101.6
3"	3 3/8	85.7	8 3/8	212.7	4 3/8	111.1	5 1/2 139.7

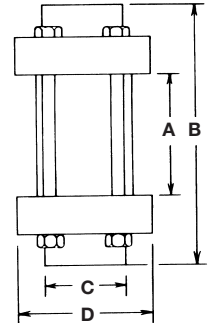

ORDERING INFORMATION		
Pipe Sizes (NPT or BSP)	PVC End Material	
	Buna-N Seals	FKM Seals
1/2"	GX050B-PV	GX050V-PV
3/4"	GX075B-PV	GX075V-PV
1"	GX100B-PV	GX100V-PV
1 1/4"	GX125B-PV	GX125V-PV
1 1/2"	GX150B-PV	GX150V-PV
2"	GX200B-PV	GX200V-PV
3"	GX300B-PV	GX300V-PV

The part numbers shown are for PVC ends. For polypropylene ends change "-PV" to "-PP". If fluttering streamers are required conclude part number with "-S". NPT threads will be supplied unless BSP is specified. Stainless steel fasteners are standard.

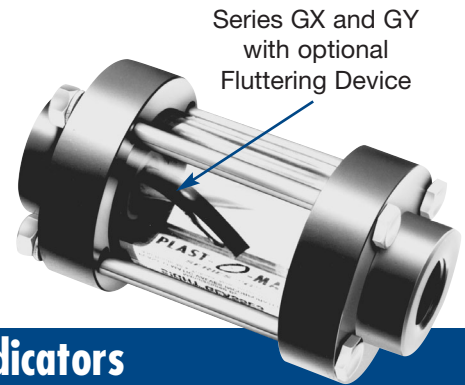

SERIES GY • Double Cylinder Wall Flow Indicators

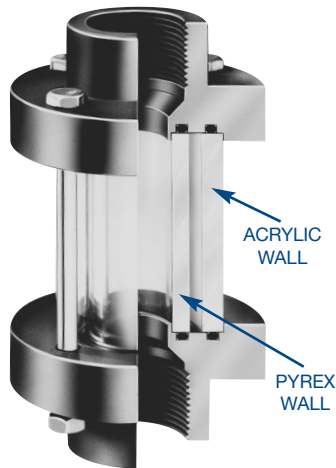

Series GY flow indicators utilize a double-wall construction and are used to indicate flow or clarity of highly corrosive or ultra-pure liquids compatible with Pyrex glass. They cannot be used with hydrofluoric acid or sodium hydroxide which will etch the Pyrex cylinder wall. They are available with PVC, or natural polypropylene ends in all sizes, and PTFE ends in 1/2", 3/4" and 1" NPT. FKM seals are standard. Pipe sizes are 1/2" through 3" NPT. BSP (British Standard Pipe) threads are also available. Optional fluttering streamers are also offered. Please consult page 4 for pressure and temperature specifications.

SERIES GY - SIGHT GLASS DIMENSIONS							
Pipe Size	"A" Visual Length In.	"A" Visual Length mm	"B" End/End Length In.	"B" End/End Length mm	"C" Diameter In.	"C" Diameter mm	"D" Diameter In. mm
1/2"	2 1/4	57.1	4 3/4	120.6	1 1/2	38.1	2 1/2 63.5
3/4"	2 1/4	57.1	4 3/4	120.6	1 1/2	38.1	2 1/2 63.5
1"	2 1/4	57.1	5 1/4	133.3	1 3/4	44.4	3 76.2
1 1/4"	2 1/2	63.5	5 7/8	149.2	2 3/8	60.3	3 1/2 88.9
1 1/2"	2 1/2	63.5	5 7/8	149.2	2 3/8	60.3	3 1/2 88.9
2"	3 1/8	79.3	7 3/8	187.3	2 7/8	73.0	4 101.6
3"	3 3/8	85.7	8 3/8	212.7	4 3/8	111.1	5 1/2 139.7

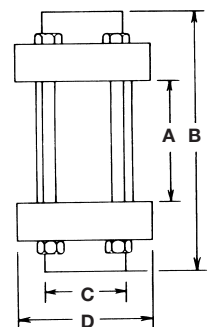

ORDERING INFORMATION	
Pipe Sizes (NPT or BSP)	PVC End Material
1/2"	GY050V-PV
3/4"	GY075V-PV
1"	GY100V-PV
1 1/4"	GY125V-PV
1 1/2"	GY150V-PV
2"	GY200V-PV
3"	GY300V-PV

The part numbers shown are for PVC ends. For polypropylene ends change "-PV" to "-PP". For PTFE ends (1/2", 3/4" and 1" only) change "-PV" to "-TF". If fluttering streamers are required conclude part number with "-S". NPT threads will be supplied unless BSP is specified. Stainless steel fasteners are standard.

SERIES GYW • Wafer-Style Double Cylinder Wall Flow Indicators

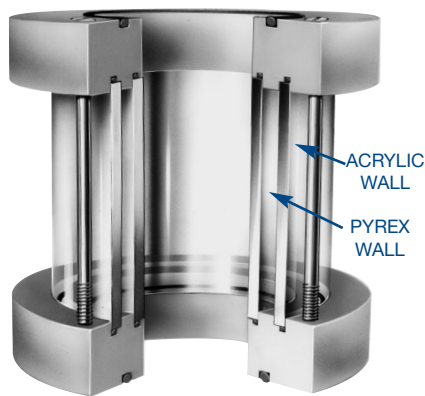

Series GYW flow indicators utilize a double-wall construction and are used on flanged piping systems handling highly corrosive and ultra-pure liquids compatible with Pyrex glass. They cannot be used with hydrofluoric acid or sodium hydroxide as they will etch the Pyrex cylinder wall. Natural polypropylene ends are standard and are also the least expensive; however PVC, Corzan CPVC, PTFE and Kynar PVDF ends are also available. FKM seals are standard. These indicators will fit 1 1/2" through 8" smooth face standard companion flanges as well as DIN (European standard) flanges. Two flange O-ring seals are supplied; therefore, other gasket materials are not required. An optional fluttering device is also offered. Please consult page 4 for pressure and temperature specifications.

ORDERING INFORMATION		
Pipe Sizes		Polypropylene End Materials
In.	mm	
1 1/2	50	GYW150V-PP
2	63	GYW200V-PP
3	90	GYW300V-PP
4	110	GYW400V-PP
6	160	GYW600V-PP
8	200	GYW800V-PP

The part numbers shown are for natural polypropylene ends. For PVC ends change "-PP" to "-PV". For Corzan CPVC ends change "-PP" to "-CP". For PTFE ends change "-PP" to "-TF". For Kynar PVDF ends change "-PP" to "-PF". If a fluttering device is required conclude part numbers with "-FD". If DIN installations are required please specify "For DIN" assembly. Stainless steel fasteners are standard.

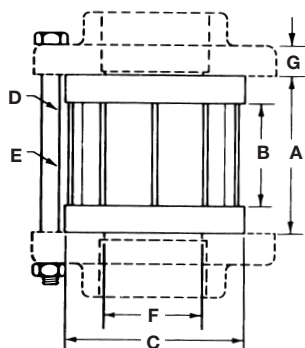

SERIES GYW - WAFER-STYLE FLOW INDICATOR DIMENSIONS												
PIPE SIZE		A WAFER ASSEMBLY LENGTH		B VISIBLE GLASS LENGTH		C WAFER ASSEMBLY DIAMETER		D BOLT SIZE	E NO. BOLTS REQ'D	F MAX FLANGE I.D. FLANGES		G A.N.S.I FLANGE THICKNESS
In.	mm	In.	mm	In.	mm	In.	mm	(Not Applicable To DIN Flanges) In.		In.	DIN mm	In.
1 1/2	50	4 1/2	114.3	2 1/2	63.3	3 3/8	92.3	1/2 - 13 x 7	4	19/16	40	11/16
2	63	5	127.0	3	76.2	4 1/8	110.4	5/8 - 11 x 7 1/2	4	21/16	52	3/4
3	90	5 1/4	133.4	3 1/4	82.6	5 7/16	143.1	5/8 - 11 x 8	4	31/16	77	11/32
4	110	5 5/8	142.9	3 5/8	92.1	6 7/8	164.3	5/8 - 11 x 9	8	45/16	101	11/32
6	160	6 1/8	155.6	4 1/4	108.0	8 11/16	220.6	3/4 - 10 x 10	8	65/16	155	17/32
8	200	6 1/4	158.8	4 1/4	108.0	10 7/8	276.2	3/4 - 10 x 10	8	85/16	205	17/16

SERIES GL • Double Cylinder Wall Level Indicators

Series GL level indicators utilize a double-wall construction to indicate the level of highly corrosive or ultra-pure liquids compatible with Pyrex glass. They cannot be used with hydrofluoric acid or sodium hydroxide as they will etch the Pyrex cylinder wall. They are available with either PVC, natural polypropylene or PTFE ends in nominal lengths of 1, 2, 3, and 4 feet. FKM seals are standard. Pipe sizes are 1/2" and 3/4" NPT. BSP (British Standard Pipe) threads are also offered. Consult page 4 for pressure and temperature specifications.

ORDERING INFORMATION			
Pipe Sizes (NPT or BSP)	Nominal Lengths Feet	Meters	PVC End Materials
1/2"	1	.31	GL050PV1
1/2"	2	.61	GL050PV2
1/2"	3	.91	GL050PV3
1/2"	4	1.22	GL050PV4
3/4"	1	.31	GL075PV1
3/4"	2	.61	GL075PV2
3/4"	3	.91	GL075PV3
3/4"	4	1.22	GL075PV4

The part numbers shown are for PVC ends. For polypropylene ends change "-PV" to "-PP". For PTFE ends change "-PV" to "-TF". NPT threads will be supplied unless BSP is specified.

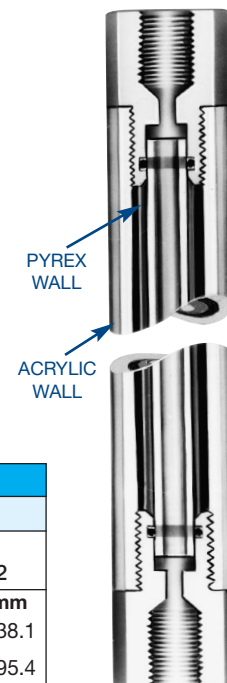

SERIES GL - LEVEL INDICATOR TUBE DIMENSIONS												
PIPE SIZES	1/2"				3/4"							
	NOMINAL LENGTH (FEET)		(METERS)		1		2		3		4	
	In.	mm	In.	mm	In.	mm	In.	mm	In.	mm	In.	mm
"A" BODY DIAMETER	1 1/2	38.1	1 1/2	38.1	1 1/2	38.1	1 1/2	38.1	1 1/2	38.1	1 1/2	38.1
"B" END/END LENGTH	15	381.0	27	685.8	39	990.6	51	1295.4	15	381.0	27	685.8
"C" VISUAL LENGTH	10	254.0	22	558.8	34	863.6	46	1168.4	10	254.0	22	558.8

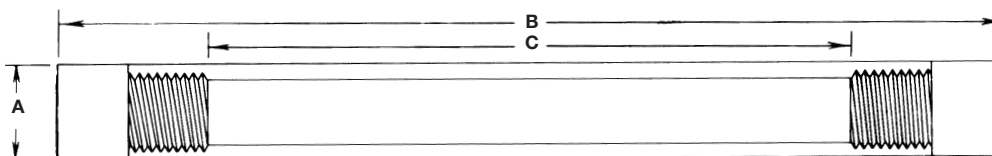

SERIES GX, GY, GYW, GL • Pressure & Temperature Specifications

PVC

FOR SERIES GX, GY and GYW

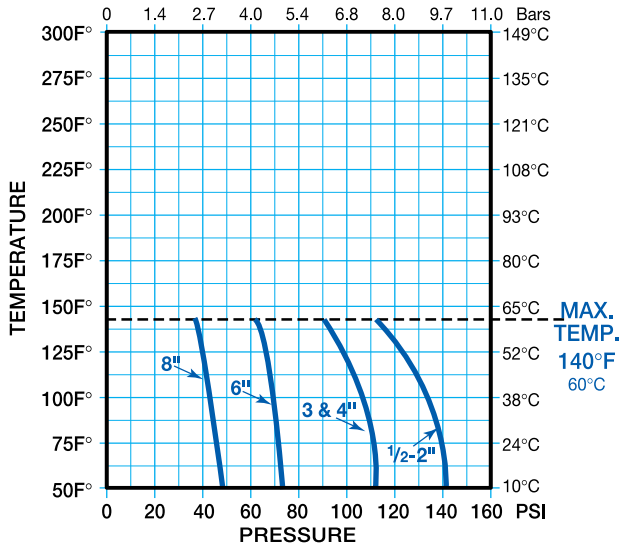

PP and Corzan CPVC

FOR SERIES GYW Only

See PP Note Below

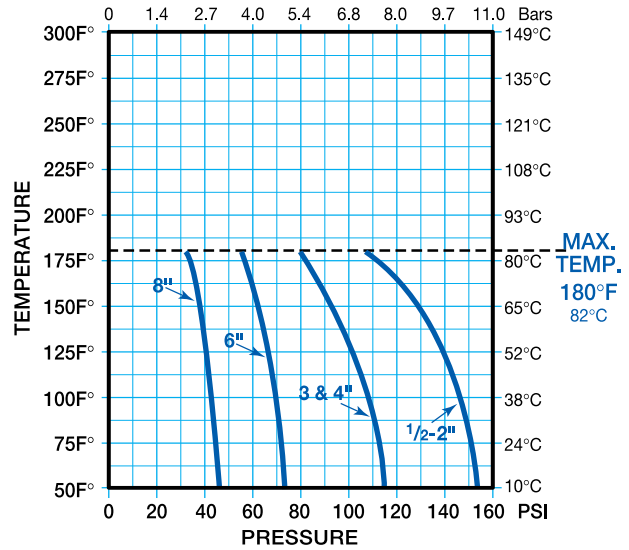

PTFE

FOR SERIES GY 1/2", 3/4" & 1" ONLY
SERIES GYW – ALL SIZES

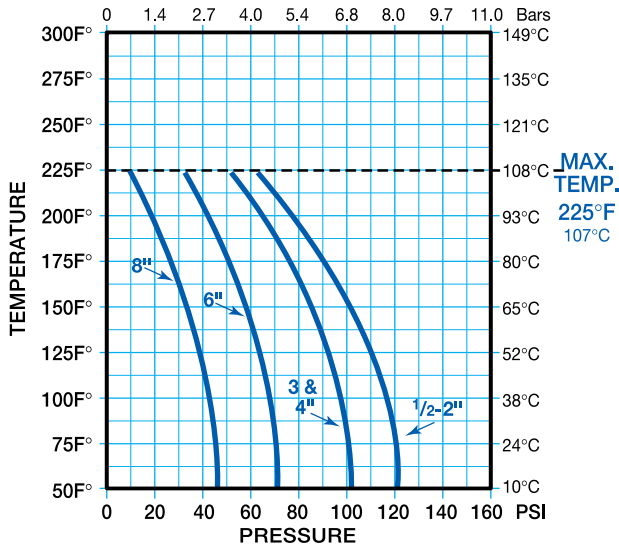

Kynar PVDF

FOR SERIES GYW ONLY

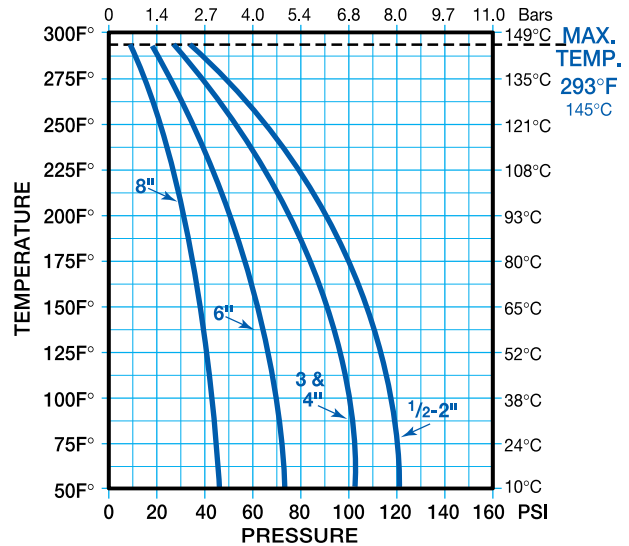

POLYPROPYLENE NOTE:

All threaded connections on Series GY and GL natural polypropylene flow and level indicators are concentrically machined and designed to handle working pressures up to 50 PSI/3 1/2 Bars at 185°F/85°C as well as full vacuum. These connections, however, could leak at almost any pressure due to the unstable nature of the natural polypropylene under pressure. If such a

leak should occur, the threaded connection should be properly fillet welded. Generally speaking, these leak problems are almost non-existent with vacuum applications or pressures under 15 PSI/1 Bar. The above note excludes Series GYW wafer indicators. For GYW only, use PP and CPVC chart above.

SERIES GL LEVEL INDICATOR NOTE:

The above charts are not to be used for Series GL level indicators. For GL level indicators use the following:

PVC ENDS	50 PSI	3.4 Bars	Maximum at 140°F/60°C
PTFE ENDS	50 PSI	3.4 Bars	Maximum at 225°F/180°C
POLYPROPYLENE ENDS			See Note Above

AUTHORIZED PLAST-O-MATIC DISTRIBUTOR

Authorized Distributor:

Aetna Plastics Corp. 1702 St. Clair Ave. Cleveland, Ohio 44114 • Tel: 800-634-3074
216-781-4421 • Fax: 216-781-4474 • sales@aetnoplastics.com • www.aetnoplastics.com