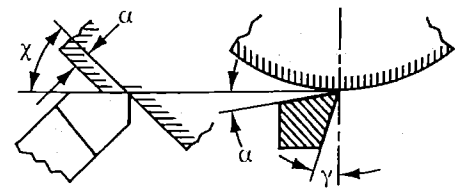
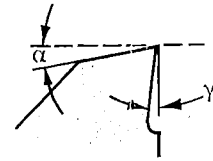
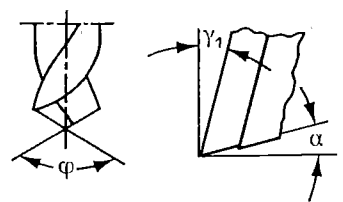
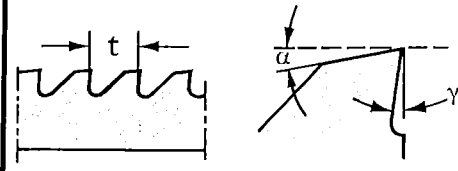

Guidelines for Machining Ensinger Engineering Plastics

Machining Operations		Turning					Milling			Drilling and Boring					Sawing				Special Measures
		 <p> α Clearance angle (°) γ Rake angle (°) χ Side angle (°) V Cutting speed ft/min S Feed mils/rev The nose radius r must be at least 0.020 in. for SINTIMID,™ r should be 0.005 to 0.010 in. </p>					 <p> α Clearance angle (°) γ Rake angle (°) V Cutting speed ft/min The feed can amount to up to 0.020 in./tooth. For SINTIMID,™ use a feed of 0.010 in. for rough cutting and 0.002 in. for finishing. </p>			 <p> α Clearance angle (°) γ_1 Rake angle (°) ϕ Point angle (°) V Cutting speed ft/min S Feed mils/rev The angle of twist β of the drill bit should be approximately 12° to 16°. </p>					 <p> α Clearance angle (°) γ Rake angle (°) V Cutting speed ft/min t Pitch mils For SINTIMID,™ use a carbide-grit-edge band saw with a continuous edge to prevent chipping. </p>				
TRADE NAME	RAW MATERIAL GROUP	α	γ	χ	V	S	α	γ	V	α	γ_1	ϕ	V	S	α	γ	V	t	
TECANAT™	Polycarbonate	5-10	6-8	45-60	950	4-20	10-20	5-15	950	8-10	10-20	90	150-300	8-12	15-30	5-8	950	115-310	In the case of fluid cooling only use pure water
TECARAN™ ABS	ABS (Acrylonitrile-Butadiene-Styrene)	5-15	25-30	15	650-1600	8-20	5-10	0-10	950-1600	8-12	10-30	90	150-650	8-12	15-30	0-5	950	75-310	In the case of fluid cooling only use pure water
TECAST VEKTON™	Cast Nylon 6	6-10	0-5	45-60	800-1600	4-20	10-20	5-15	800-1600	5-15	0-20	90-120	150-500	4-12	20-30	2-5	1600	115-310	
TECASON™ S	Polysulfone	6	0	45-60	1150-1300	4-12	2-10	1-5	800-1600	3-10	10-20	90	50-250	4-12	15-30	0-4	1600	75-195	Preheat to 240°F before drilling or sawing
TECAFLON™ PVDF	PVDF (Polyvinylidene Fluoride)	10	5-8	10	500-1600	4-12	5-15	5-15	800-1600	10-16	5-20	130	500-650	4-12	20-30	5-8	950	75-195	
TECAMID™ 6/6	Nylon 6/6	6-10	0-5	45-60	800-1600	4-20	10-20	5-15	800-1600	5-15	10-20	90	150-500	4-12	20-30	2-5	1600	115-310	
TECAFORM™	Acetal Copolymer	6-8	0-5	45-60	950-1950	4-16	5-15	5-15	800-1600	5-10	15-30	90	150-650	4-12	20-30	0-5	1600-2600	75-195	
TECAPET™ PET	PET (Polyethylene Terephthalate)	5-10	0-5	45-60	950-1300	8-16	5-15	5-15	950	5-10	10-20	90	150-300	8-12	15-30	5-8	950	115-310	Preheat to 240°F before drilling or sawing
DELIRIN®	Acetal Homopolymer	6-8	0-5	45-60	950-1950	4-16	5-15	5-15	800-1600	5-10	15-30	90	150-650	4-12	20-30	0-5	1600-2600	75-195	
NORYL®	PPO (Polyphenylene Oxide)	5-10	6-8	45-60	950	4-20	10-20	5-15	950	8-10	10-20	90	150-300	8-12	15-30	5-8	950	115-310	In the case of fluid cooling only use pure water
TECAPEEK™	Polyetheretherketone	6-12	5	45-60	950	15	5-15	5-15	550-750	12	10-20	118	400	2-8	15-30	10-15	600-950	115-195	Preheat to 240°F before drilling or sawing
ULTEM®	Polyetherimide	15	5	5	1000-2000	5-20	15	5	650-1300	5-10	5-20	70-90	300	5-15	15-30	5-10	3000-5000	100	In the case of fluid cooling only use pure water
SINTIMID®	Polyimide	0-5	8-10	60-75	300-600	1-20	5-20	5-15	300-800	5-15	5-20	90-120	500-600	3-5	15-30	0-5	3000-7000	80-130	Use hard-metal or diamond-tipped cutting tools
Reinforced Engineering Plastics*		6-8	2-8	45-60	500-650	4-20	15-30	6-10	250-350	6	5-10	120	250-300	4-12	15-30	10-15	600-950	115-195	Use hard-metal cutting tools

* Reinforcing materials: glass fibers, glass beads, carbon fibers

TM - Ensinger Industries, Inc.
 Delrin® - Dupont Company
 Ultem®, Noryl® - General Electric Company
 SINTIMID® - Ensinger GmbH

General Remarks

- Non-reinforced thermoplastics can be machined with cutting tools of high-speed steel. For reinforced materials, hard metal tools are required.
- In all cases, only properly sharpened tools are to be used.
- Due to the poor thermal conductivity of plastics, provision has to be made for good heat dissipation. Heat is best dissipated via the chips.

Dimensional Stability

- *Dimensional stability* of parts is conditional on *stress-relieved*, semi-finished materials which have to be *annealed*. The heat generated by the cutting tool otherwise inevitably leads to the release of processing stresses and deformation of the part. In the case of high material removal volumes, *intermediate heating* may be necessary after the main machining operation so as to remove the arising thermal stresses.
- Materials with high moisture absorption (e.g. polyamides) may require conditioning before machining.
- Plastics require larger finishing tolerances than metals. Furthermore, allowance has to be made for the many times greater thermal expansion.

Machining Operations

1. Turning

Guide values for cutting tool geometry are given in the table. For particularly high quality surface finishes, the tip is to be shaped as a broad-nosed finishing tool as shown in Figure 1.

For cutting off, the tool should be ground to the profile shown in Figure 2 so as to avoid a remaining stump.

On thin-walled and particularly flexible workpieces, on the other hand, it is better to work with tools that are ground to a knife-like cutting geometry. Figures 2 and 4.

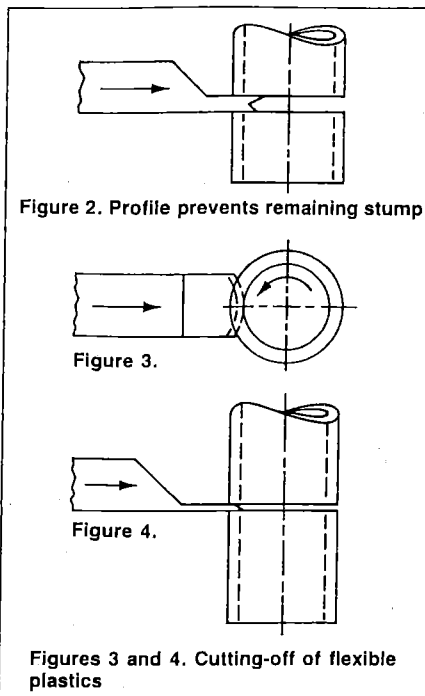
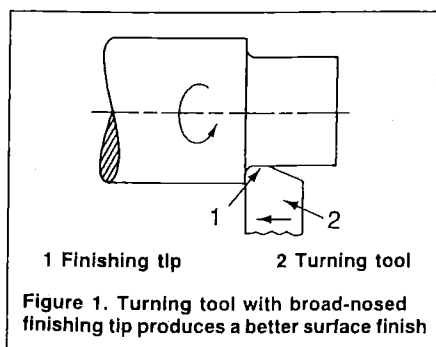

2. Milling

For plane surfaces, face milling is more economical than peripheral milling. For peripheral milling and profiling, the cutting tools should not have more than two cutting edges so that vibrations due to the number of teeth are kept to a minimum and chip widths are sufficiently large.

Optimum removal rates and surface finish are obtained with single-point tools.

3. Drilling and boring

As a general rule, it is possible to use twist drills; these should have an angle of twist of 12-16° and very smooth helical flutes for good chip removal.

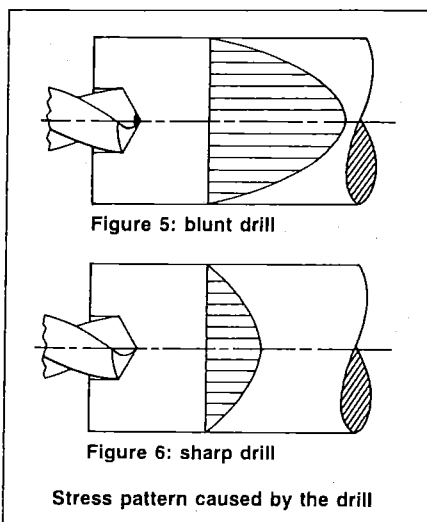

Larger diameters should be rough-drilled or produced by trepanning or internal turning.

On drilling into solid material, care must be taken to ensure that the tools are *properly sharpened*; otherwise, the developing compressive strain can build up and cause the material to split.

Reinforced plastics possess higher residual processing stresses with lower impact strength than unreinforced plastics, and are thus particularly susceptible to cracking. Where possible, these should be heated to about 240°F before drilling or sawing (heating time approximately 1 hour per 10 mm cross-section). This procedure is certainly recommended in the case of polyamide 6/6.

4. Sawing

Unnecessary generation of heat by friction is to be avoided, since sawing is generally used to cut off thick-walled parts with relatively thin tools. *Well-sharpened and heavily crossed* sawblades are therefore advised.

5. Coolant / Cutting Fluids

Make sure cutting fluids are compatible with plastics. Most metal working cooling/cutting fluids will attack plastics.

AP
Aetna Plastics
 800-634-3074

This information is only to assist and advise you on current technical knowledge and is given without obligation or liability. All trade and patent rights should be observed. All rights reserved.