



Type 14 True Union Diaphragm

Standard Features

- True Union design permits installation or repairs without expanding pipeline
- Rugged square body and bonnet are of solid thermoplastic for maximum corrosion resistance
- Uniquely designed body and bonnet together with diaphragms of new sealing designs by the state-of-the-art computer aided analysis for superior sealing
- Weir design for excellent throttling
- Full vacuum rated
- Bubble-tight sealing, even in applications such as slurries or suspended particles
- Bonnet seals to protect internals from corrosive environments
- Adjustable travel stop to prevent diaphragm from being over-tightened
- Bayonet structure to connect compressor and diaphragm for quick maintenance
- Integrally molded bottom stand for simple yet firm panel mounting
- Indicator at the top for valve position
- PVDF gas barrier, which protects EPDM backing cushion from gas permeation, is standard for all valves with PTFE diaphragm
- Low profile

Options

- 2" square operating nut for remote operation
- Stem extensions
- Locking device for tamper-proofing
- Teflon encapsulated FKM or FKM end connector o-ring seals.

Specifications

Sizes: 1/2" – 2"

Body Materials: PVC, CPVC, PP and PVDF

Bonnet Materials: PVC, PP, PPG and PVDF

End Connectors: PVC, CPVC: IPS Soc. or Thr'd
PP, PVDF: IPS & Metric(DIN)
Socket, Threaded, Butt

Diaphragms: EPDM and
3-Layer EPDM/PVDF/PTFE
Also available in Nitrile and
FKM.

Operator: Handwheel

Parts Type 14 True Union (1/2" – 2")

PARTS			
NO.	DESCRIPTION	PCS.	MATERIAL
1	Body	1	PVC, CPVC, PP, PVDF
2	Bonnet	1	PVC, PPG, PP, PVDF
25	End Connector	2	PVC, CPVC, PP, PVDF
26	Union Nut	2	PVC, CPVC, PP, PVDF
3	Diaphragm	1	EPDM, PTFE, Others
3a	Diaphragm Metal Insert	1	Stainless Steel 304
4	Cushion*	1	EPDM
5	PVDF Gas Barrier*	1	PVDF
6	Compressor	1	PVDF
7	Joint	1	Stainless Steel 304
8	Stem	1	Copper Alloy
9	Sleeve	1	Copper Alloy
10	Hand Wheel	1	PP
11	Gauge Cover	1	PC
12	Name Plate	1	PVC
13	Retaining Ring C Type	1	Stainless Steel 304
14	O-Ring (A)	1	EPDM
15	O-Ring (B)	1	EPDM
16	Thrust Ring (A)	1	UHMWPE
17	Thrust Ring (B)	1	UHMWPE
18	Bolt, Nut, Washer	4 Sets	Stainless Steel 304, Others
20	Stopper (A)	1	Copper Alloy
21	Screw	1	Stainless Steel 304
27	O-Ring (C)	2	EPDM, FKM, Others
25a	RING**	2	Stainless Steel 304

* Used for PTFE diaphragm

** Used for CPVC body, threaded end, 1/2" through 1"

- Pneumatic or electric actuation
- Manual limit switches for remote position indication by lights or for sequencing of other equipment

Type 14 True Union

Diaphragm Valves

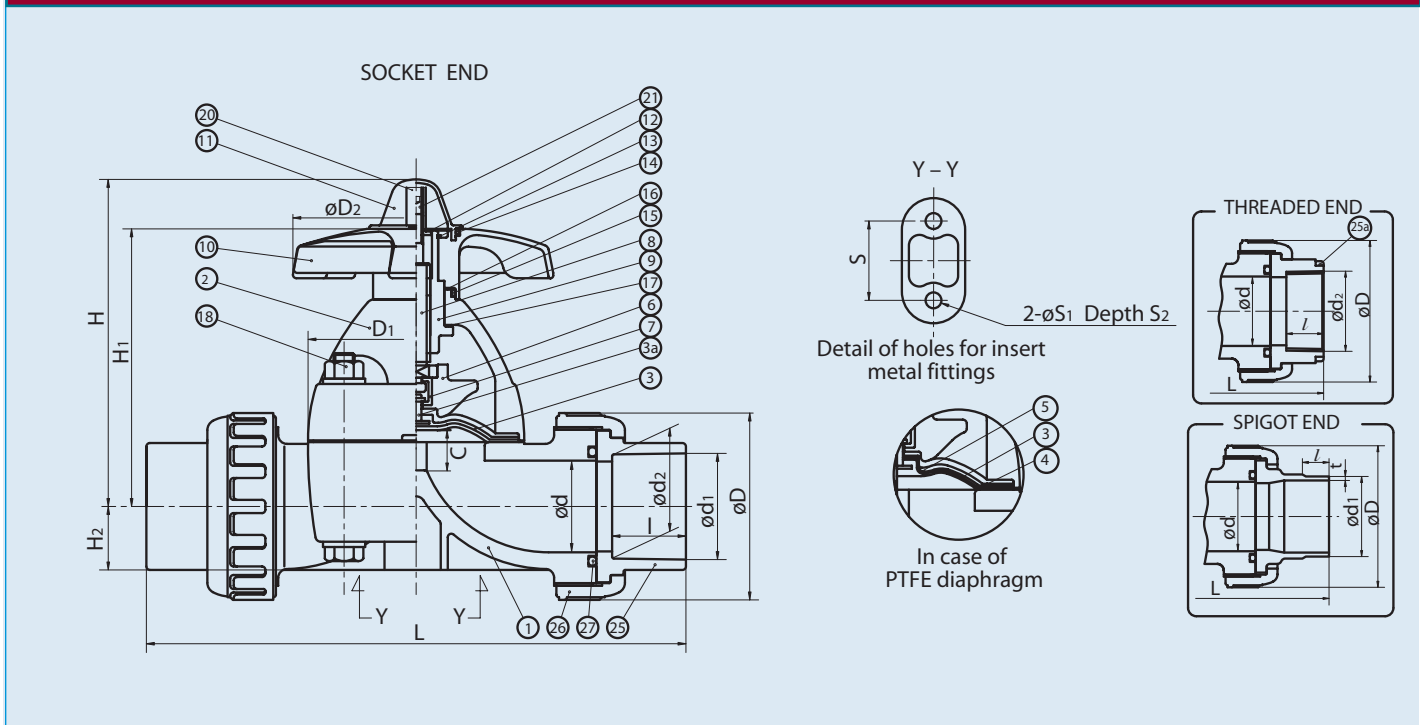

Dimensions Type 14 True Union (Sizes 1/2" – 2")

NOMINAL SIZE		SOCKET											THREADED				
		PVC, CPVC					PP, PVDF (DIN)				PP, PVDF (IPS)		d1	l	L		
		ASTM SCH 80					DIN 16962								PVC CPVC	PP PVDF	
INCHES	mm	d	d1	d2	l	L	d1	d2	l	L	d1	l	L	d1	l	PVC CPVC	PP PVDF
1/2	15	0.63	0.848	0.836	0.875	5.47	0.768	0.760	0.57	4.92	0.83	0.87	5.43	1/2-14NPT	0.59	5.04	5.04
3/4	20	0.79	1.058	1.046	1.000	6.18	0.965	0.957	0.63	5.55	1.03	1.00	6.09	3/4-14NPT	0.67	5.83	5.83
1	25	0.98	1.325	1.310	1.125	7.32	1.240	1.232	0.71	6.46	1.30	1.13	7.24	1-11 1/2NPT	0.79	6.77	6.77
1 1/4	32	1.26	1.670	1.655	1.250	7.95	1.553	1.543	0.81	6.97	1.65	1.25	7.80	1 1/4-11 1/2NPT	0.87	7.40	7.40
1 1/2	40	1.57	1.912	1.894	1.375	10.47	1.947	1.937	0.93	9.09	1.89	1.37	10.28	1 1/2-11 1/2NPT	0.98	9.65	9.65
2	50	2.05	2.387	2.369	1.500	11.54	2.461	2.445	1.08	10.79	2.36	1.50	11.54	2-11 1/2NPT	1.10	10.95	10.95

NOMINAL SIZE		SPIGOT (BUTT END)					D	D1	D2	C (LIFT)	H	H1	H2	S	S1	S2
		PP, PVDF														
		DIN 3442		PP	PVDF	L										
d1	l	t	t													
1/2	15	0.787	0.728	0.098	0.075	5.906	1.89	2.13 X 2.60	3.46	0.39	4.09	3.39	0.49	0.98	0.28	0.51
3/4	20	0.984	0.866	0.106	0.075	6.772	2.36	2.13 X 2.60	3.46	0.39	4.17	3.46	0.57	0.98	0.28	0.51
1	25	1.260	0.886	0.118	0.094	7.677	2.76	2.64 X 3.15	3.46	0.47	4.37	3.66	0.73	0.98	0.28	0.51
1 1/4	32	1.575	1.024	0.146	0.094	8.346	3.23	2.64 X 3.15	3.46	0.47	4.57	3.82	0.89	0.98	0.28	0.51
1 1/2	40	1.969	1.260	0.181	0.118	10.866	3.94	4.25 X 4.25	6.14	0.83	6.97	5.67	1.08	1.77	0.35	0.59
2	50	2.480	1.417	0.228	0.118	12.087	4.17	4.84 X 4.84	6.14	0.98	7.52	6.22	1.42	1.77	0.35	0.59

Caution

- Never remove valve from pipeline under pressure.
- Always wear protective gloves and goggles.

Type 14 True Union

Diaphragm Valves

Pressure vs. Temperature PSI, WATER, NON-SHOCK

NOMINAL SIZE		PVC		CPVC				PP			PVDF		
		ALL DIAPHRAGMS		ALL DIAPHRAGMS				ALL DIAPHRAGMS			PTFE DIAPHRAGM		
		30° F 105° F	106° F 140° F	30° F 105° F	106° F 140° F	141° F 175° F	176° F 195° F	-5° F 105° F	106° F 140° F	141° F 175° F	-40° F 140° F	141° F 175° F	176° F 210° F
INCHES	mm												
1/2	15	150	130	150	115	85	40	150	115	85	150	120	95
3/4	20	150	130	150	115	85	40	150	115	85	150	120	95
1	25	150	130	150	115	85	40	150	115	85	150	120	95
1 1/4	32	150	130	150	115	85	40	150	115	85	150	120	95
1 1/2	40	150	130	150	115	85	40	150	115	85	150	120	95
2	50	150	130	150	115	85	40	150	115	85	150	120	95

Cv Values/Wt.

NOMINAL SIZE		Cv	WT. Soc (lbs)
INCHES	mm		
1/2	15	4.8	1.1
3/4	20	5.3	1.3
1	25	8.5	2.0
1 1/4	32	11	2.4
1 1/2	40	26	5.8
2	50	43	6.4

Note:

Working temperature is different from flanged version.

Troubleshooting

What if fluid leaks when valve is fully closed?

1. Travel stop not set correctly. Adjust it per the *Asahi Operation and Maintenance* manual.
2. Solids build up inside valve. Clean inside, including weir and diaphragm.
3. Diaphragm and/or weir are worn or damaged. Change the part(s).

What if valve cannot be fully opened?

1. Diaphragm is not properly engaged with compressor. Check engagement per *Operation and Maintenance* manual.

What if fluid leaks to atmosphere?

1. Bonnet bolts not properly torqued. Retorque according to *Operation and Maintenance* manual.
2. Line pressure exceeds maximum recommended line pressure. Check or reduce system line pressure.
3. Diaphragm has ruptured or has been chemically attacked. Replace diaphragm.

Sample Specification

All Type 14 True Union diaphragm valves shall be of solid thermoplastic construction for body and bonnet with socket, threaded or butt end connectors. The valves shall come standard with a position indicator, travel stop and bonnet O-ring sealing arrangement. The valve shall be weir type with a square bonnet body sealing design and bayonet connection diaphragm. All PTFE diaphragms shall be supplied with a PVDF gas barrier between the layers of EPDM and PTFE for aggressive chemical service. PVC conforming to ASTM D1784 Cell Classification 12454-A, CPVC conforming to ASTM D1784 Cell Classification 23567-A, PP conforming to ASTM D4101 Cell Classification PPO210B67272, PPG (Bonnet Only) conforming to ASTM D4101 Cell Classification PPO110M20A21130, and PVDF conforming to ASTM D3222 Cell Classification Type II. PVC, CPVC, PP and PVDF shall be rated to 150 psi for elastomeric and PTFE diaphragms at 70 degrees F, as manufactured by Asahi/America, Inc.

Authorized Distributor:

Aetna Plastics Corp. 1702 St. Clair Ave. Cleveland, Ohio 44114 • Tel: 800-634-3074
216-781-4421 • Fax: 216-781-4474 • sales@aetnaplastics.com • www.aetnaplastics.com