



Type 75 Butterfly Valve

Specifications

Sizes: 18" – 24"
Models: Wafer Style
Operators: Gear
Bodies: PP and PVDF
Discs: PP and PVDF
Seats: EPDM , FKM and Nitrile
Seals: Same as seating material
Stems: 403 and 316 stainless steel, titanium, Hastelloy C[®]‡, etc.

‡ Trademark of Cabot Corporation

Standard Features (Sizes 18" – 24")

- Standard model (18" - 24") has polypropylene body, disc and EPDM seat.
- 403 stainless steel stem has full engagement over the entire length of the disc and is a non-wetted part totally isolated from the media.
- Bubble-tight seating.
- Only abrasion resistant, solid plastic disc and elastomeric liner are wetted parts

Options:

- Pneumatically and electrically actuated with accessories
- Lug style (stainless steel 304 and 316) as blocking and end-of-line applications
- Stems in 316 stainless steel, Titanium, Hastelloy C[®] , etc.
- 2" square nut on gear
- Stem extensions (single stem and two-piece stem)
- Locking device
- Chain operators
- Manual limit switch

Caution

- Never remove valve from pipeline under pressure.
- Always wear protective gloves and goggles.

Parts List (Sizes 18" – 24")

PARTS			
NO.	DESCRIPTION	PCS.	MATERIAL
1	Body	1	PP, PVDF
2	Disc	1	PP, PVDF
3	Seat	1	EPDM, FKM, Others
4	O-Ring (A)	2	EPDM, FKM, Others
5	O-Ring (B)	2	EPDM, FKM, Others
6	O-Ring (C)	1	EPDM, FKM, Others
7	Stem	1	Stainless Steel, 403
7a	Key (A)		Stainless Steel, 403
25	Gear Box	1	Cast Aluminum Alloy*
28	Bolt (A)	4	Stainless Steel 304
29	Bolt (D)	4	Stainless Steel 304
30	Stand	1	Steel*
1a	Ring	2	Steel*

Sample Specification

All solid thermoplastic butterfly valves (18" thru 24") shall be of the lined body design and bubble-tight seal (meeting or exceeding Class VI as defined by American National Standard Institute) with only the liner and disc as wetted parts. The disc shall be of solid, abrasion-resistant plastic, have double o-ring seals on top and bottom trunnions of the same material as the valve liner. Liner shall be molded and formed around the body, functioning as a gasket seal with convex ring design on each side of the valve for lower bolt tightening torque. Stem shall be of 403 stainless steel, non wetted and have engagement over the full length of the disc. PP shall conform to ASTM D4101 Cell Classification PP0210B67272 and PVDF conforming to ASTM D3222 Cell Classification Type II. PP and PVDF bodies shall be rated to 75 psi, size 18", and 50 psi, sizes 20" and 24" at 70 ° F. Butterfly valves shall be wafer style, as manufactured by Asahi/America Inc.

Type 75

Butterfly Valves

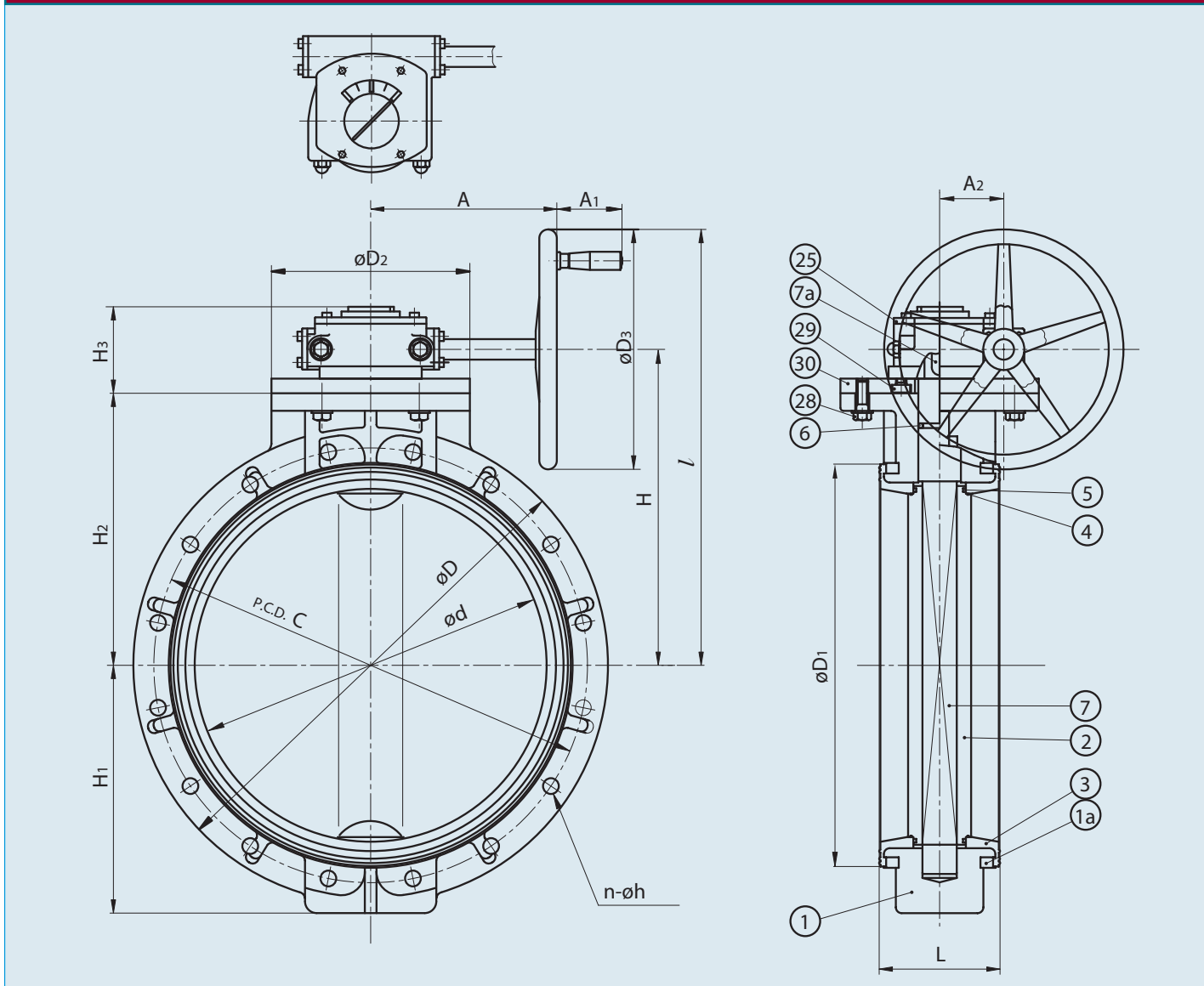

Dimensions (Sizes 18" - 24")

NOMINAL SIZE		ANSI CLASS 150					D												
INCHES	mm	d	C	n	h	PP	PVDF	D1	D2	D3	L	H	H1	H2	H3	l	A	A1	A2
18	450	17.80	22.75	16	1.25	24.92	24.80	20.67	13.39	16.14	7.05	17.52	12.40	14.57	6.22	25.59	12.56	3.35	4.33
20	500	19.76	25.00	20	1.25	26.89	26.77	22.64	13.39	16.14	7.48	18.70	13.78	15.75	6.22	26.77	12.56	3.35	4.33
24	600	23.74	29.50	20	1.38	31.22	31.10	27.01	13.39	16.14	8.23	21.26	16.69	18.31	6.22	29.33	12.56	3.35	4.33

Cv Values

Wt.(LBS)/ Vacuum Service/ Pressure vs. Temperature (PSI, WATER)*

NOMINAL SIZE		Cv (at various opening degrees)			NOMINAL SIZE		GEAR	NOMINAL SIZE		VACUUM SERVICE (inches of Mercury)	Body	PP		PVDF			
INCHES	mm	30°	60°	90°	INCHES	mm		INCHES	mm		Disc	PP		PVDF			
NOMINAL SIZE		-5 F°	141 F°	-5 F°	141 F°	176 F°	211 F°	NOMINAL SIZE		140 F°	175 F°	140 F°	175 F°	210 F°	250 F°		
INCHES	mm	18	450	75	45	75	45	30	15								
18	450	1100	5020	10890	18	450	195.00	18	450	-19.69	75	45	75	45	30	15	
20	500	1448	6620	14060	20	500	232.00	20	500	-19.69	75	30	50	30	25	15	
24	600	2130	9180	18500	24	600	285.00	24	600	-19.69	75	30	50	30	25	15	
20-24	500-600											75	30	50	30	25	15

* For lug style data consult factory

Authorized Distributor:

Aetna Plastics Corp. 1702 St. Clair Ave. Cleveland, Ohio 44114 • Tel: 800-634-3074
216-781-4421 • Fax: 216-781-4474 • sales@aetnoplastics.com • www.aetnoplastics.com