

Type G Flanged Diaphragm

Specifications

Sizes: 8" – 10"

Body Materials: PVC, PP and PVDF

Bonnet Materials: PVC, PP, PPG and PVDF

Model: Flanged (ANSI)

Diaphragms: EPDM and
3-Layer EPDM/PVDF/PTFE
Also available in Nitrile

Standard Features

- Rugged body and bonnet of solid thermoplastic for maximum corrosion resistance
- Weir design for excellent throttling
- Bubble-tight sealing, even in applications such as slurries or suspended particles
- Bonnet seals to protect internals from corrosive environments
- Built-in travel stop to prevent diaphragm from being over-tightened
- Indicator at the top for valve position
- PVDF gas barrier, which protects backing cushion from gas permeation, is standard for all valves with PTFE diaphragm

Options

- 2" square nut
- Stem extensions (single stem or two-piece stem)
- Chain operators
- Locking device for tamper-proofing
- Manual limit switches for remote position indication by lights or for sequencing of other equipment

Caution

- Never remove valve from pipeline under pressure.
- Always wear protective gloves and goggles.

Parts Type G Flanged (Sizes 8" – 10")

PARTS			
NO.	DESCRIPTION	PCS.	MATERIAL
1	Body	1	PVC, PP, PVDF
2	Bonnet	1	PVC, PP, PVDF, PPG
3	Diaphragm	1	EPDM, PTFE, Others
3a	Diaphragm Metal Insert	1	Stainless Steel 304
4	Cushion*	1	EPDM
4a	PVDF Gas Barrier*	1	PVDF
5	Compressor	1	PVDF
7	Pin	1	Stainless Steel 304
8	Stem	1	Carbon Steel
9	Sleeve	1	Cast Iron
10	Thrust Bearing (A)	1	High Carbon Chromium Bearing
11	O-Ring	1	NBR
12	Grease Nipple	1	Copper Alloy
13	Hand Wheel	1	PP
14	Name Plate	1	PVC
15	Cap	1	PP
16	Sheet Gasket	1	EPDM
17	Sheet Ring	1	Stainless Steel 304
18	Stopper	1	Chromized Steel
20	Nut	1	Stainless Steel 304
21	Gauge Cover	1	PC
23	Stud Bolt, Nut	-	Stainless Steel 304, Others
24	Bolt, Nut, Washer	-	Stainless Steel 304, Others
25	Conical Spring Washer	-	Stainless Steel 304, Others ¹
26	Upper Bonnet Liner	1 Set	Stainless Steel 304, Others ²
27	Body Liner	1 Set	Stainless Steel 304, Others ²
1a	Inserted Nut	4	Stainless Steel 304 ¹ Copper Alloy ³

* Used for PTFE diaphragm

¹ Used for PVDF body

² Used for PP and PVDF bodies

³ Used for PVC, and PP bodies

Type G Flanged

Diaphragm Valves

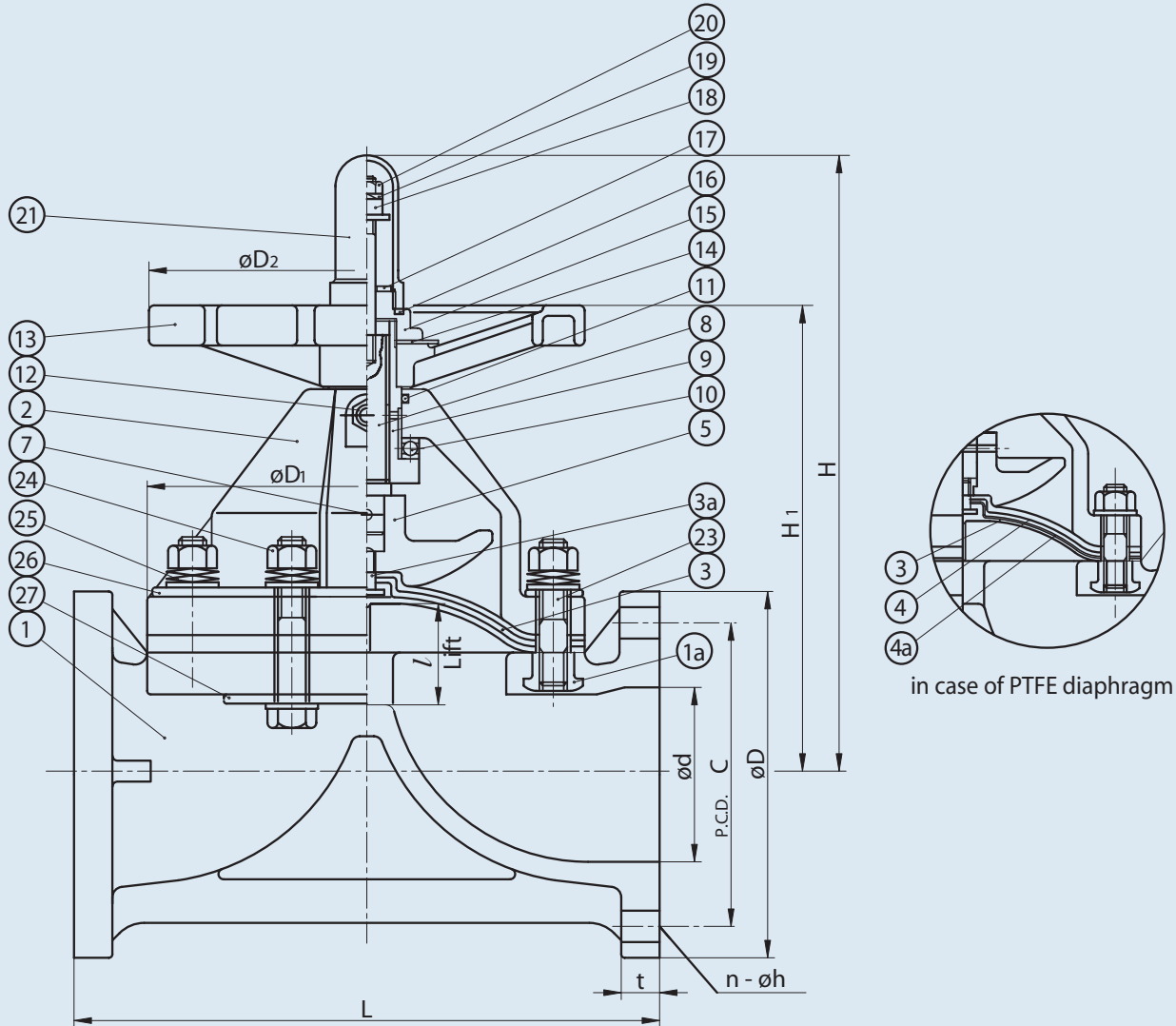

Dimensions Type G (Sizes 8" – 10")

NOMINAL SIZE		ANSI CLASS 150						t		D1	D2	l	H	H1
INCHES	mm	d	D	C	n	h	L	PVC	PP, PVDF					
8	200	7.72	13.50	11.75	8	0.88	22.24	1.10	1.26	16.93	16.14	3.74	24.69	16.50
10	250	9.72	16.00	14.25	12	0.98	26.77	1.18	1.46	21.26	22.05	5.04	30.63	20.08

Cv Values/Weight

NOMINAL SIZE		Cv	WT.
INCHES	mm		
8	200	700	140
10	250	1000	242

Pressure vs. Temperature PSI, WATER, NON-SHOCK

NOMINAL SIZE		PVC				PP						PVDF				
		ELASTOMERS		PTFE		ELASTOMERS			PTFE			ELASTOMERS		PTFE		
INCHES	mm	30° F 105° F	106° F 140° F	30° F 105° F	106° F 140° F	-5° F 105° F	106° F 140° F	141° F 195° F	-5° F 105° F	106° F 140° F	141° F 195° F	-40° F 105° F	106° F 140° F	141° F 250° F	-40° F 140° F	141° F 250° F
8	200	75	60	60	45	75	55	50	60	45	45	75	55	50	60	45
10	250	65	50	60	45	65	50	50	60	45	45	65	50	50	60	45

Type G Flanged

Diaphragm Valves

Troubleshooting

What if fluid leaks when valve is fully closed?

1. Travel stop not set correctly. Adjust it per the *Asahi Operation and Maintenance* manual.
2. Solids build up inside valve. Clean inside, including weir and diaphragm.
3. Diaphragm and/or weir are worn or damaged. Change the part(s).

What if valve cannot be fully opened?

1. Diaphragm is not properly engaged with compressor. Check engagement per *Operation and Maintenance* manual.

What if fluid leaks to atmosphere?

1. Bonnet bolts not properly torqued. Retorque according to *Operation and Maintenance* manual.
2. Line pressure exceeds maximum recommended line pressure. Check or reduce system line pressure.
3. Diaphragm has ruptured or has been chemically attacked. Replace diaphragm.

Caution

- Never remove valve from pipeline under pressure.
- Always wear protective gloves and goggles.

Sample Specification

All TYPE G flanged diaphragm valves shall be of solid thermoplastic construction for body and bonnet with molded flanged ends. The valves shall come standard with a position indicator, travel stop (to prevent over-tightening) and bonnet o-ring sealing arrangement. The valve shall be weir type with a round bonnet body sealing design and threaded stud diaphragm connection. All PTFE diaphragms shall be supplied with a PVDF gas barrier between the layers of EPDM and PTFE for aggressive chemical service. The face-to-face dimensions shall conform to TYPE G. PVC conforming to ASTM D1784 Cell Classification 12454-A, PP conforming to ASTM D4101 Cell Classification PPO210B67272, PPG (Bonnet Only) conforming to ASTM D4101 Cell Classification PPO110M20A21130, and PVDF conforming to ASTM D3222 Cell Classification Type II. PVC and PP shall be rated to 75 psi size 8" and 65 psi size 10" for elastomeric diaphragms at 70 degrees F. PVC, PP and PVDF shall be rated to 60 psi for PTFE diaphragms at 70 degrees F, as manufactured by Asahi/America, Inc.

Authorized Distributor:

Aetna Plastics Corp. 1702 St. Clair Ave. Cleveland, Ohio 44114 • Tel: 800-634-3074
216-781-4421 • Fax: 216-781-4474 • sales@aetnoplastics.com • www.aetnoplastics.com