

Ball Float Valves

The Chemline BF Series Ball Float Valve is a cost effective level control device for water or non-hazardous liquids. The valve may be mounted through a hole in the tank wall and anchored with the lock nut provided.



Polypropylene

SERIES: BF

SIZES: 1/2" – 1-1/2"

ENDS: Threaded

For Tank Level Control Will not Corrode

Features

All Plastic Construction

- Body components and ball are all plastic construction
- Plastic-coated metal arm for strength and chemical resistance

Easily Maintainable

- Body unscrews from center to expose all internal parts
- Components are all replaceable

Adjustable Float Arm

- No tools needed to adjust the ball
- 5 positions for more accurate level adjustment
- Resolves air gap between liquid level and inlet

Different Bores Available

- Allows for choice in flow rates

Designed for Safety

- Internal plunger seat eliminates fluid escaping from top or rear of arm/pivot
- Threaded outlet into tank for use with standpipe



BFB Series Ball Float Valves

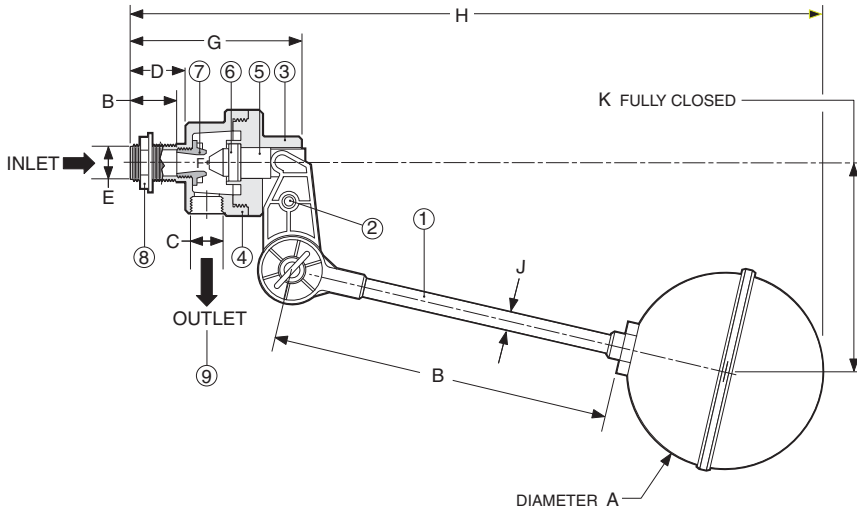

PARTS

▲ Recommended Spare Parts

No.	Part	Pcs.	Materials
1	Float/Arm	1	Polypropylene
2	Screw	1	Polypropylene
3	Body Part "A"	1	Polypropylene
4	Body Part "B"	1	Polypropylene
5	Plunger	1	Polypropylene
6▲	Disc*	1	Polyethylene
7▲	Seat	1	Polypropylene
8	Lock Nut	1	Polypropylene
9	Delivery Tubet†	1	Polypropylene

* 1", 1-1/2" has PE disc; 1/2" has PP diaphragm
 † 3-1/2" long delivery tube is supplied on 1/2" valve outlet only.

TEMPERATURE RANGE

1/2": - 20 to 70°C (-4 to 158°F)

1", 1-1/2": - 20 to 50°C (-4 to 122°F)

DIMENSIONS INCHES

Size	Type	A	B	C	D	E	Port F	G	H					J
									1	2	3	4	5	
1/2"	Standard	5.0	7.0	3/8" BSP	1.25	1/2" BSP	0.25	2.50	15.75	15.55	15.16	14.37	13.58	0.50
1/2"	High Flow	5.0	7.0	3/8" BSP	1.25	1/2" BSP	0.37	2.50	15.55	15.16	14.37	13.78	12.60	0.50
1"	Standard	7.0	14.5	1" BSP	2.25	1" BSP	0.56	4.37	27.36	26.97	25.59	24.02	21.65	0.75
1"	High Flow	7.0	14.5	1" BSP	2.25	1" BSP	0.81	4.37	27.36	26.77	25.59	23.82	21.46	0.75
1-1/2"	Standard	9.0	15.0	1-1/4" BSP	2.37	1-1/2" BSP	0.87	5.37	31.10	30.71	29.53	28.15	25.79	0.75
1-1/2"	High Flow	9.0	15.0	1-1/4" BSP	2.37	1-1/2" BSP	1.25	5.37	31.10	30.51	29.33	27.56	25.39	0.75

DIMENSIONS INCHES

Size	Type	K Closed					M Open					P	R
		1	2	3	4	5	1	2	3	4	5		
1/2"	Standard	2.36	3.62	5.12	6.89	8.07	8.27	9.65	10.83	12.20	12.99	1.00	1.00
1/2"	High Flow	3.15	5.12	6.38	7.48	8.98	8.27	9.65	10.83	12.20	12.99	1.00	1.00
1"	Standard	5.12	7.87	10.63	13.39	15.75	18.50	20.87	22.83	24.21	25.39	2.01	2.01
1"	High Flow	5.51	8.46	11.42	13.78	16.14	18.50	20.87	22.83	24.21	25.39	2.01	2.01
1-1/2"	Standard	5.12	6.69	10.04	12.80	15.75	21.10	23.03	25.39	27.17	29.53	2.37	2.46
1-1/2"	High Flow	5.51	8.27	12.01	14.76	16.73	21.10	23.03	25.39	27.17	29.53	2.37	2.46

WORKING PRESSURES

FLOW RATES USGPM WATER

C_v VALUES

Size	Type	PSI (Water Level at "K")	vs. Line Pressure – PSI						USGPM at 1 psi ΔP
			10	30	50	85	100	150	
1/2"	Standard	150	2.9	5.0	6.5	8.4	9.1	11.2	0.9
1/2"	High Flow	85	6.5	11.3	14.5	19.0	-	-	2.0
1"	Standard	100	14.1	24.5	31.5	41.2	45.0	-	4.5
1"	High Flow	50	29.5	51.1	65.9	-	-	-	9.3
1-1/2"	Standard	100	22.5	39.0	50.0	65.5	71.0	-	7.0
1-1/2"	High Flow	50	46.4	80.4	103.8	-	-	-	14.6

ORDERING EXAMPLE

Chemline Ball Float Valve	BF	B	005	-HF
Body Material	B – PP			
Size	005 – 1/2" 015 – 1-1/2" 010 – 1"			
Flow	Blank – Standard Flow HF – High Flow			

Example: Chemline BF Series Ball Float Valve, PP, 1/2", high flow.

Authorized Distributor:

Aetna Plastics Corp. 1702 St. Clair Ave. Cleveland, Ohio 44114 • Tel: 800-634-3074
 216-781-4421 • Fax: 216-781-4474 • sales@aetnaplastics.com • www.aetnaplastics.com