

PVC Butterfly Valves—Model-C

150 psi at 73°F water—non-shock

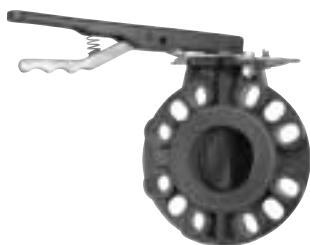

The Chemtrol Model-C Butterfly Valve is intended for general water applications. With National Sanitation Foundation (NSF) listing, it is ideal for potable water service. The Model-C valve has also been successfully used to handle mild acidic solutions and medium concentrations of alkaline solutions. However, this valve should not be used in water lines receiving chlorine gas or bleach injection. Nor should it be used in aquatic center recirculation lines, which receive low level bleach injection. Simple construction of the Model-C butterfly valve results from its unique design.

It does not have a traditional rubber seat inside the bore of the one-piece molded body. Rather, EPDM is molded over a brass disk. This EPDM material is compressed between the brass portion of the disk and straight bore through the PVC body and creates the sealing mechanism for this butterfly valve. At assembly, two hardened 416 stainless steel shafts with splines on the inboard ends are swaged into the brass inner disk to become the upper and lower stems.

Features

- Glass-filled TFE bearing-bushings, extending almost the entire lengths of the upper and lower stems, transfer the hydraulic side load on the disk and evenly distributes it to the valve body to ensure low bearing stress with long, trouble-free operation.
- Rigid brass disk is encapsulated with EPDM.
- Durable one-piece molded PVC body.
- Built-in O-ring face-seals require no gaskets between mating flanges.
- Valve accessories for manual operation in overhead or underground systems and other special needs are available. Refer to page 24.
- Refer to the *Chemtrol Valve Actuation Guide* for a full selection of electrical and pneumatic actuators with accessories, including plastic housings. Mounting kits are available for field or factory assembly.

Notes

C_v Table

Size	Degrees Open								
	10°	20°	30°	40°	50°	60°	70°	80°	90°
2	2.5	8	18	33	50	73	100	131	166
2 1/2	3.7	12	27	49	74	109	148	195	247
3	4.3	16	35	62	94	135	180	235	290
4	8.6	34	76	137	215	310	420	550	690
6	17.5	67	200	265	410	580	790	1040	1340
8	20.8	83	190	320	530	770	1060	1380	1780
10	50.0	195	430	775	1200	1775	2700	3100	4000

Dimensions—Weights

Valve Size	A	B	C	D	E	F	G	H	I	J	K	L	Handle			Approx. ¹ Wt./Lbs.
													M	N	P	
2	1.94	1.69	6.41	1.25	3.94	3.29	3.25	2.75	0.44	3.26	0.37	0.50	10.50	1.01	6.19	2.02
2 1/2	2.44	1.81	7.19	1.25	4.13	3.63	3.25	2.75	0.44	3.26	0.37	0.50	10.50	1.01	6.19	2.56
3	2.87	1.81	7.75	1.15	4.43	3.91	3.25	2.75	0.44	3.26	0.37	0.50	10.50	1.01	6.19	2.92
4	3.82	2.06	9.08	1.25	5.31	4.57	3.25	2.75	0.44	3.26	0.50	0.65	10.50	1.01	6.19	5.04
6	5.76	2.20	11.22	1.25	7.09	5.64	3.25	2.75	0.44	3.26	0.56	0.78	13.75	1.01	6.19	8.99
8	7.74	2.36	13.66	1.25	8.00	6.83	3.25	2.75	0.44	3.26	0.56	0.78	13.75	1.01	6.19	14.27
10	9.57	2.68	16.49	1.25	9.84	8.40	5.00	4.01	0.56	4.76	0.74	1.06	Gear Operator Only			27.70

¹ Operator not included in weight.

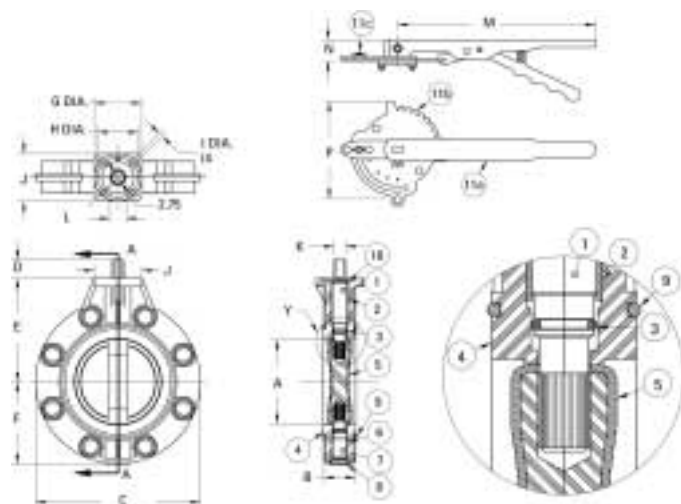

Installation and Maintenance Instructions for these valves appear on page 12. For more insight into the selection of materials, refer to *Materials*, page 1. *Actuation Mounting Data* for Butterfly Valves may be found on page 21, followed by a complete listing of *Valve Accessories*. For the specific relationships of pressure vs. temperature ratings, refer to *Engineering Data*, page 33. For *Chemtrol Valve Standards*, see page 35.

Construction

Part	Material
1. Upper Stem	416 Stainless Steel
2. Upper Bushing	Glass-Filled PTFE (Teflon)
3. O-Ring Stem Seal (2 required)	EPDM – Upper and Lower Stem
4. Body	PVC
5. Disk	EPDM Encapsulated Brass
6. Lower Bushing	Glass-Filled PTFE (Teflon)
7. Lower Stem	416 Stainless Steel
8. Plug	LDPE (Polyethylene)
9. O-Ring Face-Seal (2 required)	EPDM
10. Snap Ring (2 required)	Zinc Plated Steel
11. Lever Handle Assembly	
Handle w/Lever Lock	Malleable Iron
Throttling Plate	Zinc Plated Steel
Position Lock	Zinc Plated Steel

Chemtrol Figure Numbers

Disk Material	Operating Mechanism	2" – 10" Figure No. ¹
EPDM	Lever Handle ²	W45BG-E-3
	Gear Operator	W45BG-E-5

¹ 10" is available with gear operator only.

² Includes throttle plate and lock.

Authorized Distributor:

**Aetna Plastics Corp. 1702 St. Clair Ave. Cleveland, Ohio 44114 • Tel: 800-634-3074
216-781-4421 • Fax: 216-781-4474 • sales@aetnaplastics.com • www.aetnaplastics.com**