

Technical
Information and
Product Range

Electric Actuators

EA 11/21/31/42



► Intelligence in motion



Our actuators at a glance

Solid basis: EA 11

The EA 11 is our basic version for the open-close operation of smaller torques. Nominal torque is 10 Nm, peak torque 20 Nm. Two additional limit switches can be installed for feedback. The EA 11 is expandable with a fail-safe return and a heating element.

Interesting array of accessories: EA 21

From the EA 21 model and up, we offer you a variety of supplementary kits to choose from. Compared to the basic EA 11 model, this actuator indicates operation readiness and has a duty cycle of 100%. Also included in the EA 21 range of accessories are cycle time extension, cycle time monitoring, cycle counter, motor current monitoring, position signalization and a positioner.

High torques: EA 31 and EA 42

The EA 31 and the EA 42 are not only well equipped with a lot of extras, they also feature very high torques. This enables automating a wide range of valves. While the EA 31 features a peak torque of up to 120 Nm, the EA 42 even goes to 250 Nm. Both actuators are ideal for all kinds of control tasks.



EA 11



EA 21



EA 31



EA 42

The details that make life easier

Experience modularity

You know what you want and what you need – down to the last detail. That is why GF Piping Systems now offers a complete range of actuators from the low-cost version to the fully equipped high-end version.

Our new actuator series can be outfitted according to your exact requirements and wishes, allowing you to focus on what is important and forget about extras that you don't need.

Thanks to their modular design, the actuators can be configured specifically to your application. You can choose to fit our actuators with, for example, two additional limit switches for end position indication. Or perhaps you would like a fail-safe return with built-in battery that moves the valve into the defined safety position. For applications with temperatures below -10°C we provide a heating element as well.

The EA 11 forms the basis of the new actuator series. From the EA 21 and up, GF Piping Systems offers a large selection of interesting accessories to choose from.

Safe and controlled all along the line

The actuator status can be transmitted directly to the control station. This extra measure of safety is warranted by the integrated, isolated ready-for-operation no-

tification, which is mandatory for all EA 21 models and higher. And you can control the actuator even better with the monitoring print:

- extend and check cycle time
- check the current of the motor
- count the cycles

For optimal process control, our PE 25 positioner in combination with position signalization is the perfect solution.

Quality at its best

Our new electric actuators are not only characterized by the sophisticated technical details, but also by the first-rate quality. The number of cycles, for example, is very high compared to competing products. Our gear mechanism is very robust. The fiberglass reinforced plastic housing is flame retardant and splashproof. All GF Piping Systems actuators are equipped with an integrated emergency manual override.

Global players – worldwide in use

All our actuators are of course equipped with a wide-range power supply designed for all the customary voltages. This means their worldwide use poses no acceptance problems and actuators from GF Piping Systems also have all the prevalent approvals such as CE, UL and CSA. Our standard interface enables equipping a large variety of valves with our technology.

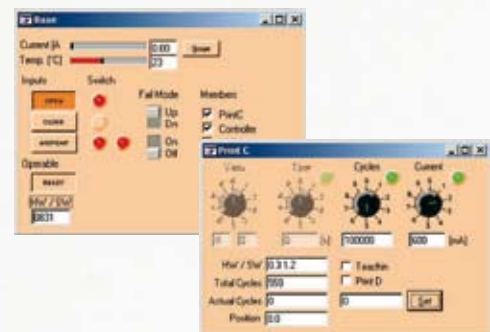



The modular design of our innovative actuators means more benefits for you. You decide what torque you need and which accessories are useful to you. The EA 11 is the ideal starter model. For more demanding tasks, we offer the EA 21, the EA 31 and the EA 42.



Installation has never been so easy and so fast. No screws to fasten - just one click with a screw driver. The spring tenses, you insert the cable and you're set.

Just flip a switch – wouldn't that be great. With our actuators you can. You don't need to decide on a plant configuration and you don't need a laptop.



The test adapter kit for the digital RS 232 interface is one of the most sophisticated details. With the precise and comprehensive diagnosis, you know immediately where the error is. This frequently eliminates the need for troubleshooting, reduces downtime and saves you valuable time – not to mention money too.



Georg Fischer electric actuators activate valves safely and reliably, even in harsh environments.

The photograph shows the secondary cooling system in a supermarket. Temperatures here can fall to -33°C . ABS ball valves type 546 with EA 11 were installed for this application.

The specific customer requirements were a high number of cycles and robust electronics for reliable operation.

Sophistication in detail

We at GF Piping Systems strive for excellence and we achieve this by surpassing your requirements. That is why we insisted on designing user-friendly actuators.

In practical terms, this means:

- Spring-type terminals for easy and fast wiring
- DIP switch or rotary multistep switch for uncomplicated parameter setting
- Test adapter for connecting to an RS 232 interface on PC or laptop

Your benefits at a glance

- flexible configuration due to modular design
- easy storage
- reduced costs thanks to fast installation
- easy handling
- intelligent, self-learning accessories
- numerous monitoring and control options
- extra safety with fail-safe return and accumulator (optional)
- high level of quality
- long service life thanks to sturdy construction and the best electronics available
- universal use with wide-range power supply and standard interfaces
- certified worldwide: CE, UL, CSA

Technical specifications

Electric actuators 11/21/31/42



	EA 11	EA 21	EA 31	EA 42
	✓	✓	✓	✓
	✓	✓	✓	✓
	✓	✓	✓	✓
Nominal torque M_{dn}	10 Nm	10 Nm	60 Nm	100 Nm
Peak torque	20Nm	20Nm	120 Nm	250 Nm
Control time	5 s/ 90° at M _{dn}	5 s/ 90° at M _{dn}	15 s/ 90° at M _{dn}	25 s/ 90° at M _{dn}
Actuating angle	max. 180°, set to 90°	max. 180°, set to 90°	max. 180°, set to 90°	max. 180°, set to 90°
L/W/H	129/122/138	150/122/167	150/122/190	150/122/208
Cycles at 20°C and M_{dn}	150,000	250,000	100,000	75,000
Flanges	F05	F05	F07	F07
Housing materials	PP fiberglass reinforced, flame retardant, external stainless steel screws	PP fiberglass reinforced, flame retardant, captive stainless steel screws externally	PP fiberglass reinforced, flame retardant, captive stainless steel screws externally	PP fiberglass reinforced, flame retardant, captive stainless steel screws externally
Position indicator	optical, integrated	optical, integrated	optical, integrated	optical, integrated
Emergency manual override	integrated	integrated	integrated	integrated
Rated voltage	100- 230V, 50/60 Hz 24V = /24V, 50/60 Hz	100- 230V, 50/60 Hz 24V = /24V, 50/60 Hz	100- 230V, 50/60 Hz 24V = /24V, 50/60 Hz	100- 230V, 50/60 Hz 24V = /24V, 50/60 Hz
Rated voltage tolerance	+/- 10%	+/- 10%	+/- 10%	+/- 10%
Rated output	22 VA at 24V AC/DC 40 VA at 100- 230V AC	22 VA at 24V AC/DC 40 VA at 100- 230V AC	32 VA at 24V AC/DC 40 VA at 100 - 230V AC	40 VA at 24V AC/DC 60 VA at 100 - 230V AC
Direct impedance	230V, 100k 24V, 4k7	230V, 100k 24V, 4k7	230V, 100k 24V, 4k7	230V, 100k 24V, 4k7
Duty cycle ED	40% at 25°C/15 min	100% (6)	50%	35%
Protection class	IP 65 per EN 60529 (3) UL/CSA: for interior use	IP 65 per EN 60529 (3) UL/CSA: for interior use	IP 65 per EN 60529 (3) UL/CSA: for interior use	IP 65 per EN 60529 (3) UL/CSA: for interior use
Overload protection	current / time dependent (resetting) (1)	current / time dependent (resetting) (1), temperature-dependent	current / time dependent (resetting) (1), temperature-dependent	current / time dependent (resetting) (1), temperature-dependent
Overvoltage category (5)	II	II	II	II
Electrical connections	Connector plug 3 P+ E per EN 175301-803 (formerly DIN 43650), additional cable entry point for PG11	Connector plug 3 P+ E per EN 175301-803 (formerly DIN 43650), screw cable gland M20x1.5 per ISO 724	Connector plug 3 P+ E per EN 175301-803 (formerly DIN 43650), screw cable gland M20x1.5 per ISO 724	Connector plug 3 P+ E per EN 175301-803 (formerly DIN 43650), screw cable gland M20x1.5 per ISO 724
Pollution grade (5)	2	2	2	2
Height over NN (UL/CSA)	< 2000m	< 2000m	< 2000m	< 2000m
Ambient temperature	-10° to + 45°C (2)	-10° to + 50°C (2)	-10° to + 50°C (2)	-10° to + 50°C (2)
Allowable humidity	max. 80% to 31°C (4)	max. 90% relative humidity, non condensing	max. 90% relative humidity, non condensing	Max. 90% relative humidity, non condensing

[1] Overload protection of the motor is dimensioned so that the motor and the power supply board are protected. As soon as the load is in the torque range, the actuator runs again.

[2] At temperatures below -10°C and if there is condensation, the heating element no. 198 190 086 should be built in.

* pending

[3] Protection class IP67 for use of cable glands and vertical installation.

[4] Linear decrease up to 50% relative humidity at 40°C.

[5] According to DIN EN 61010-1

[6] Reduced Duty cycle for UL certification

Dimensional drawings

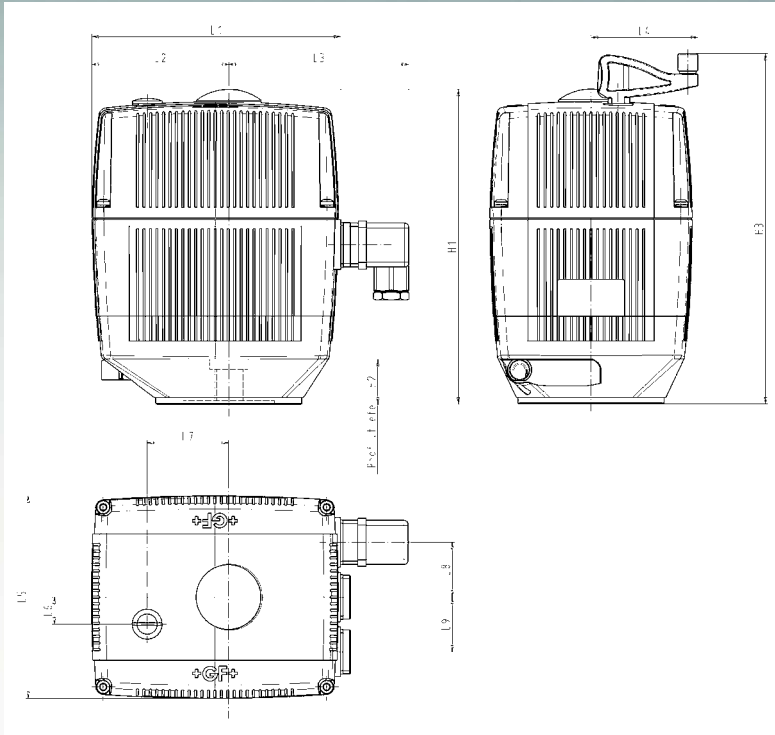

Wiring diagram

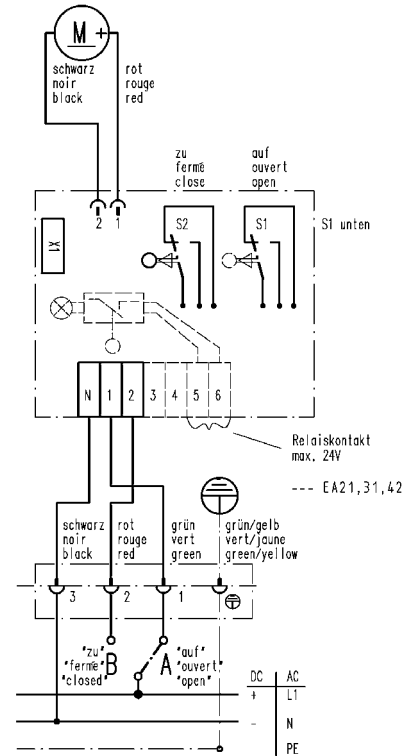

	L1	L2	L3	L4	L5	L6	L7	L8	L9	H1	H2	H3
EA 11	130	82.5	88	64.3	122	16	49	33	-	137.5	20	159.5
EA 21	150	82.5	108	64.3	122	16	49	33	33	167	20	188.5
EA 31	150	82.5	108	64.3	122	16	49	33	33	190	25	211.5
EA 42	150	82.5	108	64.3	122	16	49	33	33	208	25	229.5

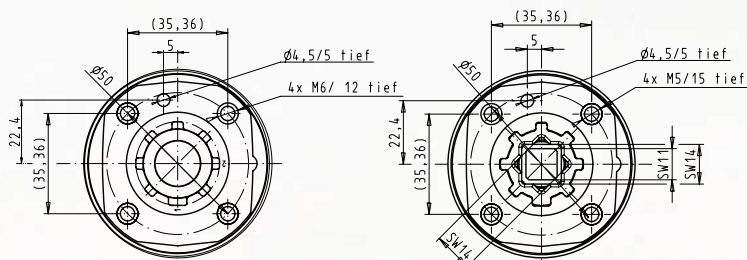

EA 11/F05

EA 21/F05

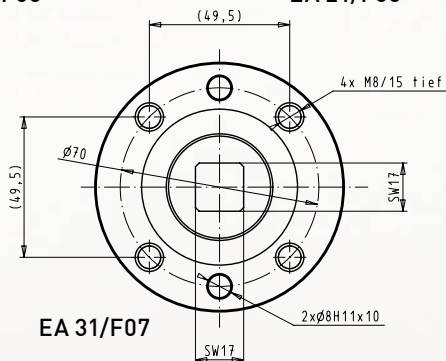

EA 31/F07

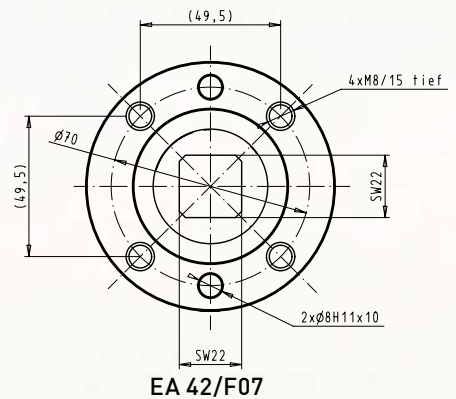

EA 42/F07

Accessories



	EA 11	EA 21	EA 31	EA 42
Code 100 - 230 V ~	198 150 180	198 150 182	198 150 184	198 150 186
Code 24 V =/~	198 150 181	198 150 183	198 150 185	198 150 187
Fail-safe return	✓	✓	✓	✓
Heating element	✓	✓	✓	✓
Battery	✓	✓	✓	✓
Monitoring print		✓	✓	✓
Cycle extension		✓	✓	✓
Cycle monitoring		✓	✓	✓
Cycle counter		✓	✓	✓
Motor current monitoring		✓	✓	✓
Position signalization		✓	✓	✓
Positioner PE25		✓	✓	✓
Limit switch kits Ag-Ni, Au, NPN, PNP	✓*	✓	✓	✓
Limit switch kit middle positioning		✓	✓	✓
Kit for 4 limit switches		✓	✓	✓
Test adapter kit for RS 232 interface		✓	✓	✓

* only Ag-Ni

For added safety: Heating element and fail-safe return



Heating element and fail-safe return incl. battery set

Code	Description
199 190 085	Fail-safe return with battery
199 190 086	Heating element
199 190 087	Heating element + fail-safe return with battery

We have an interesting package to offer: a heating element and a fail-safe return including a battery set. Both elements are of course also available separately.

The heating element comes into operation at temperatures below 10°C and prevents condensation.

The fail-safe return assures that the actuator drives into a safe position in case of power failure.

Accessories

For extra feedback: additional limit switches

Limit switch kits
AG-Ni, Au

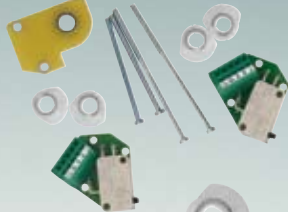

Limit switch kits
NPN/PNP



Limit switch kit
Middle position



Technical data	Code	Description
250V ~, 6A	199 190 092	Kit with 2 additional limit switches Ag-Ni
30V =, 100mA	199 190 093	Kit with 2 additional limit switches Au
10-30V=, 100mA	199 190 096	Kit with 2 additional limit switches NPN
10-30V=, 100mA	199 190 095	Kit with 2 additional limit switches PNP
	199 190 097	Installation set for 4 limit switches
	199 190 094	Middle positioning kit

We supply additional limit switches that give you feedback on the actual position of your actuator. Kits are available for two additional limit switches – in the standard materials silver-nickel. For smaller currents, gold is used. We also have kits for additional limit switches in NPN / PNP. For PNP the signal is positive, for NPN negative.

For four additional limit switches, we offer an installation set with a backing plate for more stability. The limit switches must be ordered separately.

To actuate a 3-way ball valve, our middle positioning kit is the ideal solution. The limit switches contained in this kit detect the middle position.

For a better overview: the monitoring print with cycle time extension, cycle time monitoring, cycle counter and motor current monitoring

Code	Description
199 190 099	Monitoring print
199 190 080	Cycle time extension (Vario)
199 190 082	Cycle time monitoring
199 190 083	Cycle counter
199 190 081	Motor current monitoring

The monitoring print can be fitted with up to four BCD switches as well as with position signalization.

By extending the cycle time you can prevent water hammer in your system because the valve closes slower.

Monitoring the cycle time helps to quickly identify problems with the valve or in the system.

The cycle counter informs you when the set cycles have been reached. The DIP switch allows you to decide if you wish the motor to stand still or continue running.

If a valve starts running sluggishly over the years because of media that crystallize out or other contaminants, the motor current will increase. By monitoring the motor current, you recognize and locate such problems immediately. You can also determine the motor current at which you want to shut off.

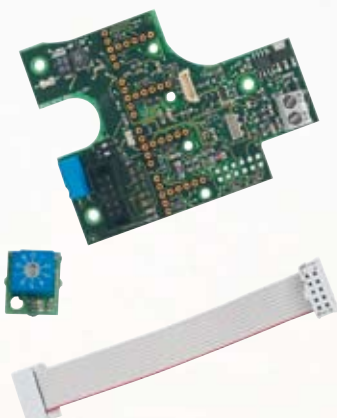

Monitoring print with BCD
switch

Accessories

For more accuracy: position signalization and positioner

Position signalization



PE 25 Positioner



Code	Description
199 190 084	Position signalization
199 190 100	PE 25 positioner

With position signalization, the exact mechanical position of a valve is collected. The signal output takes place on the controller or monitoring print via a 4-20 mA current signal.

Ideal solution: Position signalization combined with the PE25 positioner and the monitoring print.

The PE 25 positioner makes it possible to control the valve position continuously. The set value can be 0-10V or 4-20mA.

Feedback on the valve position (actual value) is done via position signalization with 4-20mA.

For easy analysis: Test adapter kit with RS232 interface

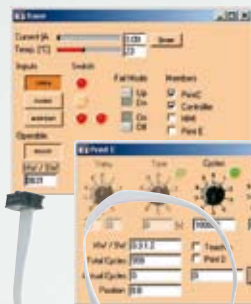





Code	Description
198 151 426	Test adapter kit for RS232 interface (software, RS232 adapter, instruction manual)

Before you call in the repair service, you already know where the problem lies. Because our new test adapter kit automatically detects which accessories have been installed and what the source of the defect is. Fast and reliable – without expensive service technicians. And all you need for this is a laptop/PC.

Test adapter kit

Application options

	EA 11 	EA 21 	EA 31 	EA 42 
2-way ball valves up to DN 50 e.g. KH 546 DN10 - DN50	✓	✓	✗	✗
2-way ball valves up to DN 100 e.g. KH 546 DN65 - DN100	✗	✗	✓	✗
3-way ball valves up to DN 50 e.g. KH 343	✗	✓	✗	✗
Butterfly valves e.g. AK 567/568	✗	✗	✓	✓

Overview of our actuators

Base + Actuator EA	2-way ball valve							3-way ball valve				Butterfly valve			
	546							343				567	568		
= Type	11	21 DN10 - DN50 31 DN65 - DN100						21				31 to DN150 42 from DN200			
Note	107	130	131	132	133	134	135	175	176	177	178	140	141	142	143
PVC-U	metric	metric	metric	metric	ANSI	BS	JIS	horizontal	horizontal	horizontal	vertical	Wafer	Lug	Lug ANSI	Lug JIS
PVC-C	•	•			•	•	•	•				•	•	•	•
ABS	•	•			•	•	•	•				•	•	•	•
PP-H	•		•		•	•	•		•			•	•	•	•
PP-N															
PVDF	•			•	•	•	•			•		•	•	•	•
PVDF															

Order information

Description	Code
Actuator EA11 100-230 V~	198 150 180
Actuator EA11 24 V~/~	198 150 181
Actuator EA21 100-230 V~	198 150 182
Actuator EA21 24 V~/~	198 150 183
Actuator EA31 100-230 V~	198 150 184
Actuator EA31 24 V~/~	198 150 185
Actuator EA42 100-230 V~	198 150 186
Actuator EA42 24 V~/~	198 150 187
Limit switch kit Ag-Ni	199 190 092
Limit switch kit Au	199 190 093
Limit switch kit PNP	199 190 095
Limit switch kit NPN	199 190 096
Limit switch kit for middle position	199 190 094
Installation set for 4 limit switches	199 190 097
Fail-safe return with battery	199 190 085
Heating element	199 190 086
Heating element + fail-safe return with battery	199 190 087

Description	Code
Monitoring print	199 190 099
Cycle time extension (Vario)	199 190 080
Cycle time monitoring	199 190 082
Cycle counter	199 190 083
Motor current monitoring	199 190 081
Position signalization	199 190 084
Positioner PE25	199 190 100
Positioner PE25 with galv. isolation	199 190 101
Test adapter kit for RS 232 interface	198 151 426
Adapterset for F05 SW14/11	198 000 587
Adapter SW14 for F05	198 204 057
Adapter sleeve SW11 for F05	198 803 145
Battery set (replacement)	198 151 317
Emergency manual key	198 151 307
Emergency manual cover set (screw plug)	198 000 503
Plug set	198 000 502

Authorized Distributor:

**Aetna Plastics Corp. 1702 St. Clair Ave. Cleveland, Ohio 44114 • Tel: 800-634-3074
216-781-4421 • Fax: 216-781-4474 • sales@aetnaplastics.com • www.aetnaplastics.com**